

Retrofitting Trelleborg Engine Mounts to Pre-GHG17 Heavy-Duty Engines

01-102

FLA COE
FLB COE
FLD Conventional
Business Class
FLC 112 Conventional

> Century Class Conventional
> Argosy
Cargo
> Columbia
> 122SD and Coronado

> Business Class M2
> Cascadia
> 108SD/114SD
New Cascadia

**Freightliner
Service Bulletin**

Description of Revisions: *General information and parts list have been updated.*

General Information

Vehicles built prior to GHG17 use engine mounts produced by Parker LORD. See **Fig. 1**. If the rear LORD engine mounts are not available from the PDC, the new version from Trelleborg can be adapted to replace the original mounts. It is recommended to replace both rear and front mounts, if one LORD engine mount is being replaced with a Trelleborg engine mount. In some installations, the original mount is an assembly that includes an additional spacer. See **Fig. 2**. In these cases, the spacer needs to be removed from the original assembly and installed between the new mount and the engine leg. Use the parts in **Table 1** and the steps below to convert to the rear Trelleborg mounts. The front mounts are interchangeable.

IMPORTANT: Do not use the fasteners for the LORD rear engine mount for the Trelleborg rear engine mount.

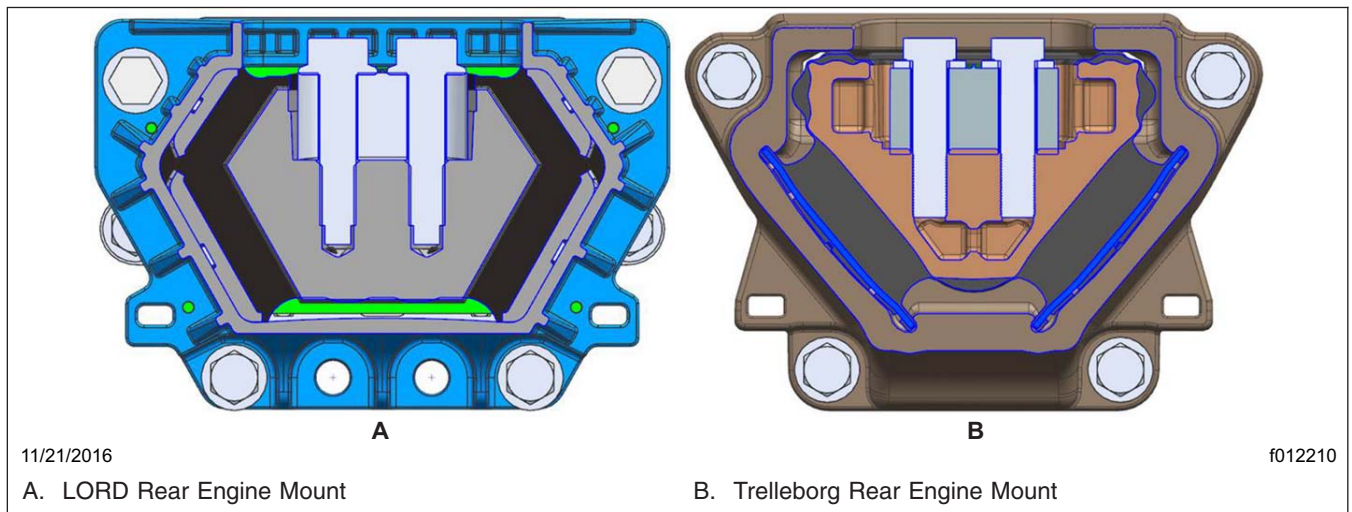

Fig. 1, Rear Engine Mounts by Manufacturer

FLA COE
FLB COE
FLD Conventional
Business Class
FLC 112 Conventional

> Century Class Conventional
> Argosy
> Cargo
> Columbia
> 122SD and Coronado

> Business Class M2
> Cascadia
> 108SD/114SD
New Cascadia

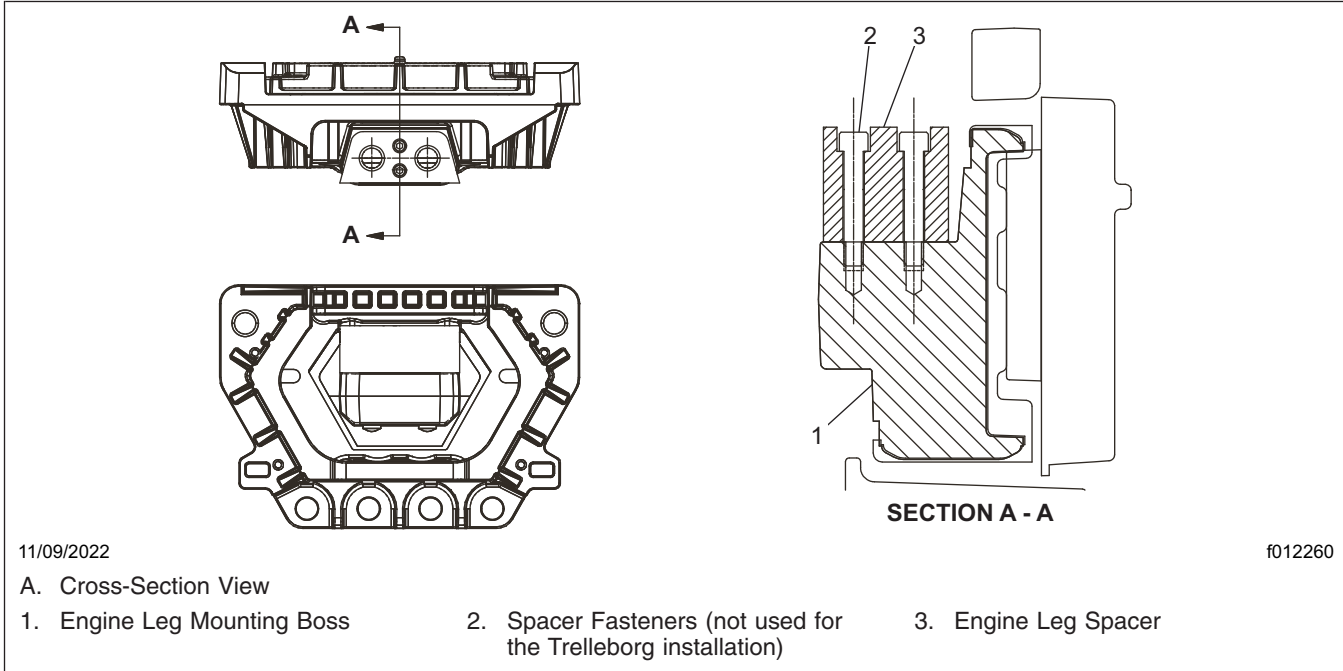

Fig. 2, LORD Engine Mount Assemblies with Spacers

Parts

Parts are available through the PDC. See [Table 1](#).

Trelleborg Engine Mounts Retrofit Parts List				
LORD Engine Mount	Original Fastener	Trelleborg Mount	Replacement Fastener	Position
LORJ26185 27	23-13421-300	01-35313-001	23-14068-080	Rear Mount
LORJ26185 28	23-13421-300	01-35313-000	23-14068-080	Rear Mount
LORJ26185 29	23-13421-300	01-35313-001	23-14068-080	Rear Mount
LORJ26185 30	23-13421-300	01-35313-000	23-14068-080	Rear Mount
A01-31455-004	23-13421-375	01-35313-000	23-14284-100	Rear Mount
A01-31455-015	23-13421-375	01-35313-001	23-14284-100	Rear Mount
A01-31455-006	23-13421-425	01-35313-000	23-14068-120	Rear Mount
A01-31455-007	23-13421-425	01-35313-001	23-14068-120	Rear Mount
A01-31455-008	23-13421-425	01-35313-000	23-14068-150	Rear Mount
A01-31455-009	23-13421-375	01-35313-000	23-14284-100	Rear Mount
A01-31455-010	23-13421-375	01-35313-001	23-14284-100	Rear Mount
LORJ21246 60	23-13539-500	01-33963-000	23-13539-500 and 23-09114-004	Upper Front Mount
LORJ21247 21	23-13833-112	01-133964-000	23-13934-065 and 23-09114-004	Lower Front Mount

Table 1, Trelleborg Engine Mounts Retrofit Parts List

Retrofitting Trelleborg Engine Mounts to Pre-GHG17 Heavy-Duty Engines

01-102

FLA COE
FLB COE
FLD Conventional
Business Class
FLC 112 Conventional

> Century Class Conventional
> Argosy
Cargo
> Columbia
> 122SD and Coronado

> Business Class M2
> Cascadia
> 108SD/114SD
New Cascadia

**Freightliner
Service Bulletin**

Procedure

1. Park the vehicle on a level surface, shut down the engine, and set the parking brake. Chock the tires.
2. Follow the engine mount repair process in the applicable workshop manual to remove the rear mounts.
3. If there is a spacer attached to the original mount, remove it and save it for the assembly process.
4. Follow the applicable workshop manual procedures to install the new mount on the frame rail.
5. Use the new fasteners to secure the engine leg and spacer, if applicable, to the new mount. Tighten the fasteners 229 lbf-ft (310 N·m).
6. Use the applicable workshop manual to replace the front engine isolators.

Warranty

This is an informational bulletin only. Warranty does not apply.