



Installation Instructions

BENDIX AD-IS® AIR DRYER SERVICE REPLACEMENT KIT

AD-IS® Air Dryer Reservoir Module

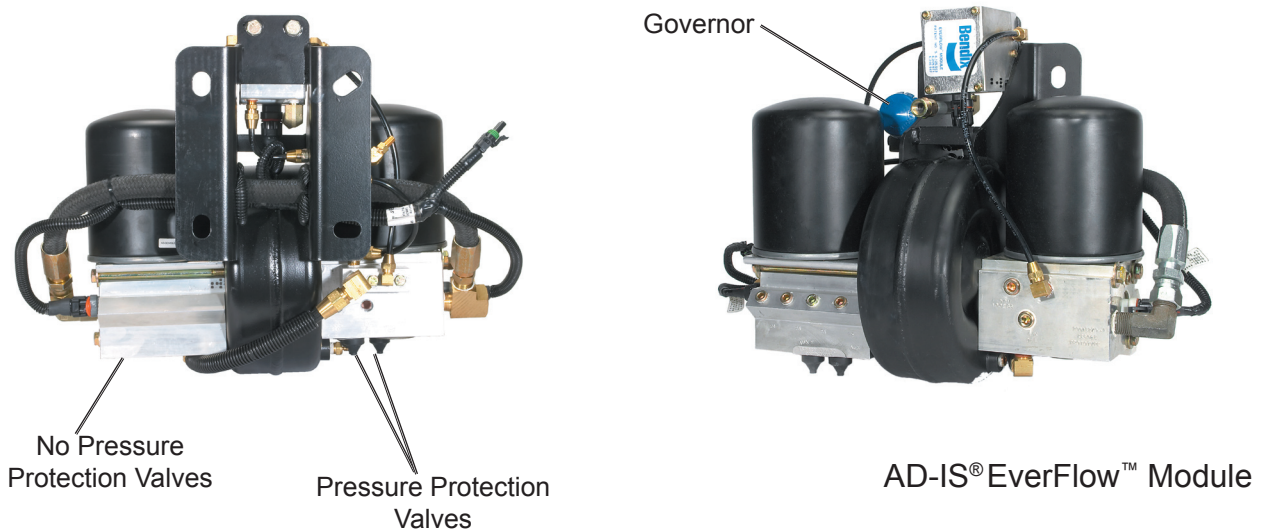
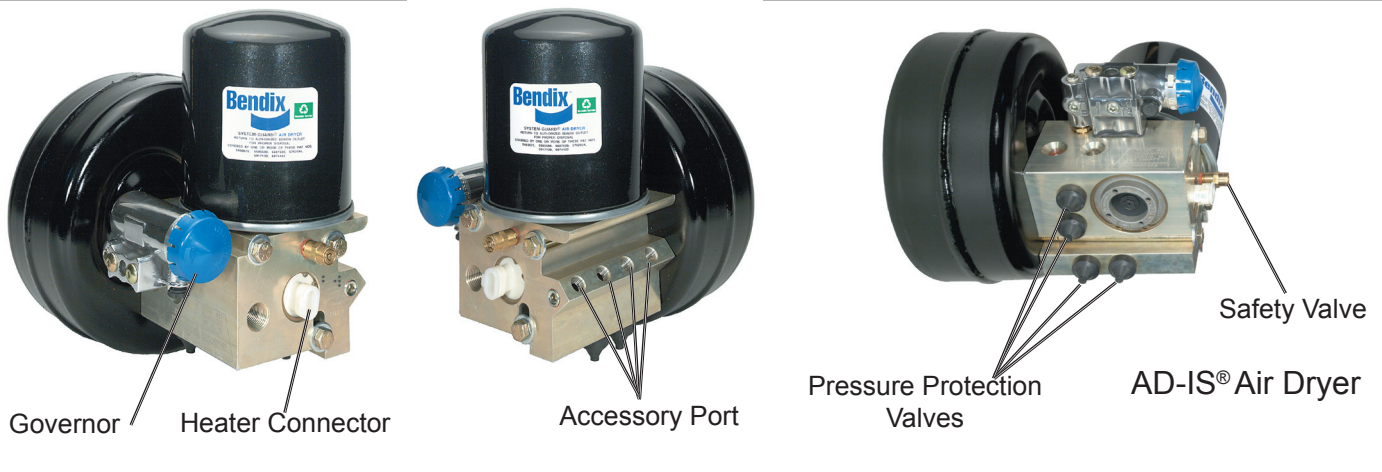
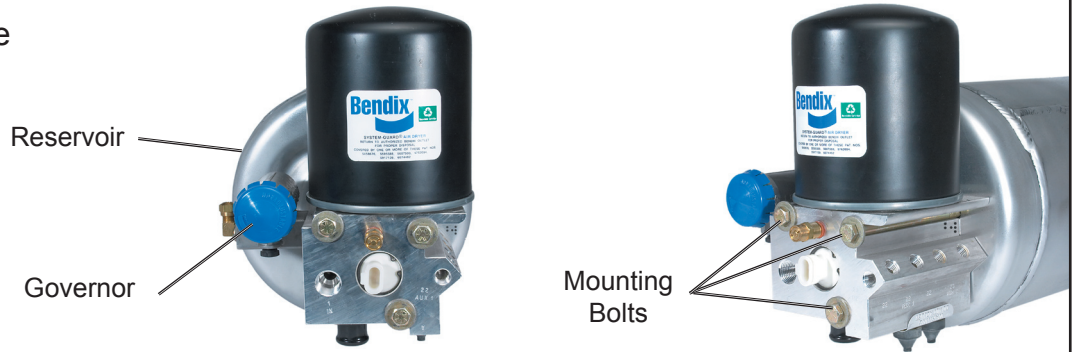

Figure 1 AD-IS® Air Dryer Configurations

WARNING! PLEASE READ AND FOLLOW THESE INSTRUCTIONS TO AVOID PERSONAL INJURY OR DEATH:

When working on or around a vehicle, the following general precautions should be observed at all times.

1. Park the vehicle on a level surface, apply the parking brakes, and always block the wheels. Always wear safety glasses.
2. Stop the engine and remove ignition key when working under or around the vehicle. When working in the engine compartment, the engine should be shut off and the ignition key should be removed. Where circumstances require that the engine be in operation, **EXTREME CAUTION** should be used to prevent personal injury resulting from contact with moving, rotating, leaking, heated or electrically charged components.
3. Do not attempt to install, remove, disassemble or assemble a component until you have read and thoroughly understand the recommended procedures. Use only the proper tools and observe all precautions pertaining to use of those tools.
4. If the work is being performed on the vehicle's air brake system, or any auxiliary pressurized air systems, make certain to drain the air pressure from all reservoirs before beginning ANY work on the vehicle. If the vehicle is equipped with an AD-IS® air dryer system or a dryer reservoir module, be sure to drain the purge reservoir.
5. Following the vehicle manufacturer's recommended procedures, deactivate the electrical system in a manner that safely removes all electrical power from the vehicle.
6. Never exceed manufacturer's recommended pressures.
7. Never connect or disconnect a hose or line containing pressure; it may whip. Never remove a component or plug unless you are certain all system pressure has been depleted.
8. Use only genuine Bendix® replacement parts, components and kits. Replacement hardware, tubing, hose, fittings, etc. must be of equivalent size, type and strength as original equipment and be designed specifically for such applications and systems.
9. Components with stripped threads or damaged parts should be replaced rather than repaired. Do not attempt repairs requiring machining or welding unless specifically stated and approved by the vehicle and component manufacturer.
10. Prior to returning the vehicle to service, make certain all components and systems are restored to their proper operating condition.
11. For vehicles with Antilock Traction Control (ATC), the ATC function must be disabled (ATC indicator lamp should be ON) prior to performing any vehicle maintenance where one or more wheels on a drive axle are lifted off the ground and moving.

GENERAL

This kit is to be used to replace the AD-IS® air dryer. It is not a retrofit kit. This kit cannot be installed on vehicles that do not have an existing AD-IS® air dryer. As shown in Figure 1, there are various applications of AD-IS® air dryers. Be sure to verify the air dryer you are replacing has the same accessory port configuration, air dryer heater voltage and, if applicable, the presence of pressure protection valves in the bottom housing. Do not install the air dryer included in this kit if it does not match the one being removed.

VEHICLE PREPARATION

1. Park the vehicle on a level surface and prevent movement by means other than the brakes.
2. Drain all reservoirs to 0 p.s.i. **CAUTION:** Always depressurize the air dryer purge reservoir, and all other reservoirs on the vehicle to 0 p.s.i. before servicing the air dryer.

DISASSEMBLY

1. Identify and mark all connections on the air dryer for ease of installation.
2. Disconnect all air line connections and the heater connector to the air dryer.
3. Remove and retain the air dryer mounting bolts.
4. Remove the air dryer and the sealing rings.

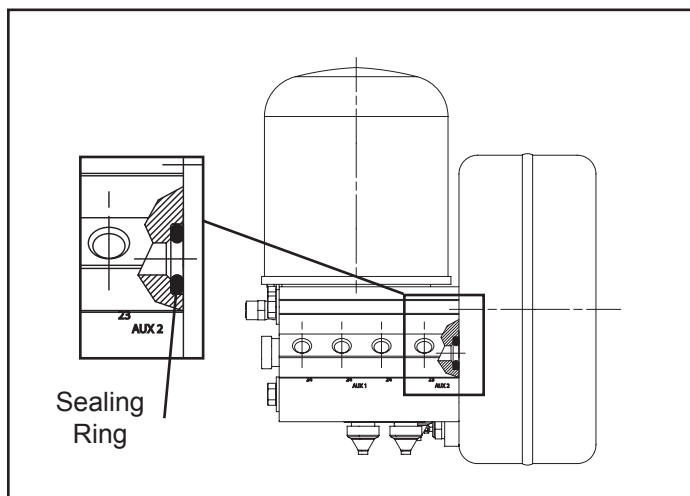

Figure 2 AD-IS® Air Dryer Sealing Ring

CLEANING & INSPECTION

1. Using a clean rag, wipe the air dryer mounting surface and sealing ring contact area.
2. Inspect for physical damage to the air dryer mounting surface.
3. Ensure that the air dryer sealing ring is installed in its groove properly.
4. Using the air dryer mounting bolts that were removed during disassembly, secure the air dryer. Torque to 360-420 inch pounds.
5. Connect all the air lines to the new air dryer as marked during the disassembly process.

TESTING THE AD-IS® AIR DRYER

Before placing the vehicle in service, perform the following tests.

1. Close all reservoir drain valves.
2. Build up system pressure to governor cut-out and note that the AD-IS® air dryer purges with an audible burst of air, followed immediately by approximately 30 seconds of air flowing out of the purge valve.
3. “Fan” the service brakes to reduce system air pressure to governor cut-in. Note that the system once again builds to full pressure and is followed by a purge at the AD-IS® air dryer exhaust.

For AD-IS® EverFlow™ air dryer installations: Note that the system once again builds to full pressure and is followed by a purge at the other AD-IS® EverFlow™ air dryer exhaust.

4. It is recommended that the total air system be tested for leakage to assure that the air dryer(s) do not cycle excessively.

For additional information see Bendix publication BW5057 “Air Brake Handbook.”

