

GENERAL SAFETY GUIDELINES



WARNING! PLEASE READ AND FOLLOW THESE INSTRUCTIONS

TO AVOID PERSONAL INJURY OR DEATH:

When working on or around a vehicle, the following guidelines should be observed **AT ALL TIMES**:

- ▲ Park the vehicle on a level surface, apply the parking brakes and always block the wheels. Always wear personal protection equipment.
- ▲ Stop the engine and remove the ignition key when working under or around the vehicle. When working in the engine compartment, the engine should be shut off and the ignition key should be removed. Where circumstances require that the engine be in operation, **EXTREME CAUTION** should be used to prevent personal injury resulting from contact with moving, rotating, leaking, heated or electrically-charged components.
- ▲ Do not attempt to install, remove, disassemble or assemble a component until you have read, and thoroughly understand, the recommended procedures. Use only the proper tools and observe all precautions pertaining to use of those tools.
- ▲ If the work is being performed on the vehicle's air brake system, or any auxiliary pressurized air systems, make certain to drain the air pressure from all reservoirs before beginning ANY work on the vehicle. If the vehicle is equipped with a Bendix® AD-IS® air dryer system, a Bendix® DRM™ dryer reservoir module, a Bendix® AD-9si®, AD-HF®, or AD-HFⁱ air dryer, be sure to drain the purge reservoir.
- ▲ Following the vehicle manufacturer's recommended procedures, deactivate the electrical system in a manner that safely removes all electrical power from the vehicle.
- ▲ Never exceed manufacturer's recommended pressures.
- ▲ Never connect or disconnect a hose or line containing pressure; it may whip and/or cause hazardous airborne dust and dirt particles. Wear eye protection. Slowly open connections with care, and verify that no pressure is present. Never remove a component or plug unless you are certain all system pressure has been depleted.
- ▲ Use only genuine Bendix® brand replacement parts, components and kits. Replacement hardware, tubing, hose, fittings, wiring, etc. must be of equivalent size, type and strength as original equipment and be designed specifically for such applications and systems.
- ▲ Components with stripped threads or damaged parts should be replaced rather than repaired. Do not attempt repairs requiring machining or welding unless specifically stated and approved by the vehicle and component manufacturer.
- ▲ Prior to returning the vehicle to service, make certain all components and systems are restored to their proper operating condition.
- ▲ For vehicles with Automatic Traction Control (ATC), the ATC function must be disabled (ATC indicator lamp should be ON) prior to performing any vehicle maintenance where one or more wheels on a drive axle are lifted off the ground and moving.
- ▲ The power **MUST** be temporarily disconnected from the radar sensor whenever any tests **USING A DYNAMOMETER** are conducted on a vehicle equipped with a Bendix® Wingman® system.
- ▲ You should consult the vehicle manufacturer's operating and service manuals, and any related literature, in conjunction with the Guidelines above.



WARNING: Not all wheels and valve stems are compatible with Bendix® Air Disc Brakes. Use only wheels and valve stems approved by the vehicle manufacturer to avoid the risk of valve stem shear and other compatibility issues.



WARNING: AVOID CREATING DUST. POSSIBLE CANCER AND LUNG DISEASE HAZARD.

While Bendix Spicer Foundation Brake LLC does not offer asbestos brake linings, the long-term effects of some non-asbestos fibers have not been determined. Current Occupational Safety and Health Administration (OSHA) Regulations cover exposure levels to some components of non-asbestos linings, but not all. The following precautions must be used when handling these materials.

Avoid creating dust. Compressed air or dry brushing must never be used for cleaning brake assemblies or the work area.

- ▲ Bendix recommends that workers doing brake work must take steps to minimize exposure to airborne brake lining particles. Proper procedures to reduce exposure include working in a well-ventilated area, segregation of areas where brake work is done, use of local filtered ventilation systems or use of enclosed cells with filtered vacuums. Respirators approved by the Mine Safety and Health Administration (MSHA) or National Institute for Occupational Safety and Health (NIOSH) should be worn at all times during brake servicing.
- ▲ Workers must wash before eating, drinking or smoking; shower after working, and should not wear work clothes home. Work clothes should be vacuumed and laundered separately without shaking.
- ▲ OSHA Regulations regarding testing, disposal of waste and methods of reducing exposure for asbestos are set forth in 29 Code of Federal Regulations §1910.001. These Regulations provide valuable information which can be utilized to reduce exposure to airborne particles.
- ▲ Material Safety Data Sheets on this product, as required by OSHA, are available by contacting the Bendix Tech Team at 1-800-247-2725, option 2, or techteam@bendix.com.

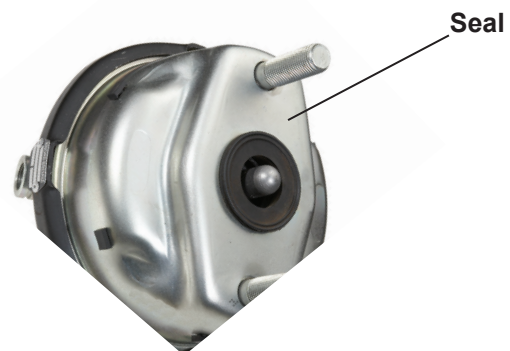

Figure 2 – Service Brake Chamber

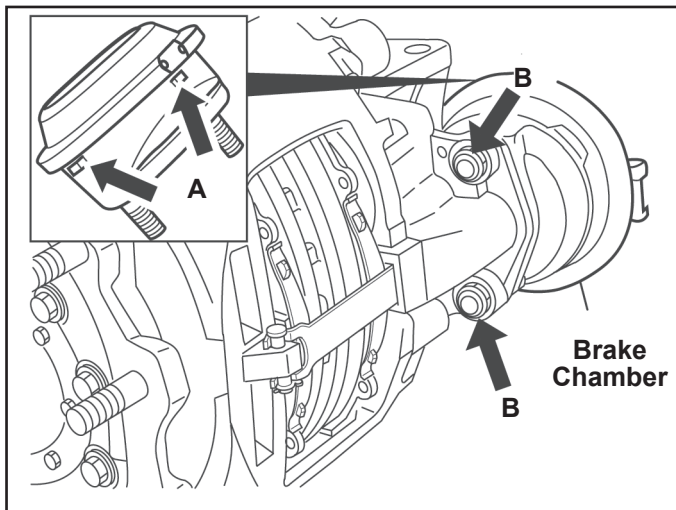

Figure 3 - Brake Chamber Installation

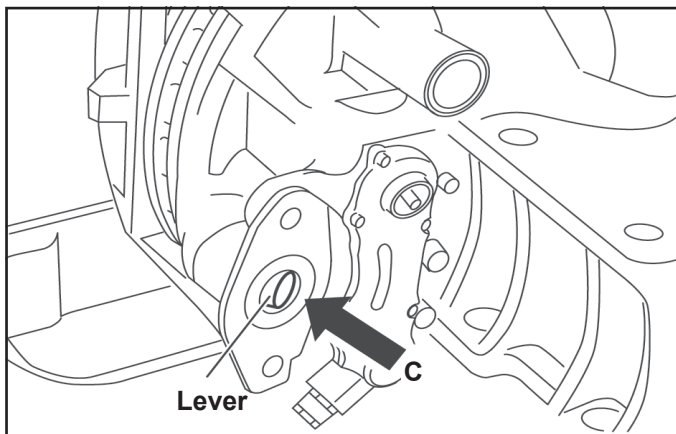

Figure 4 - Brake Chamber Mounting Flange

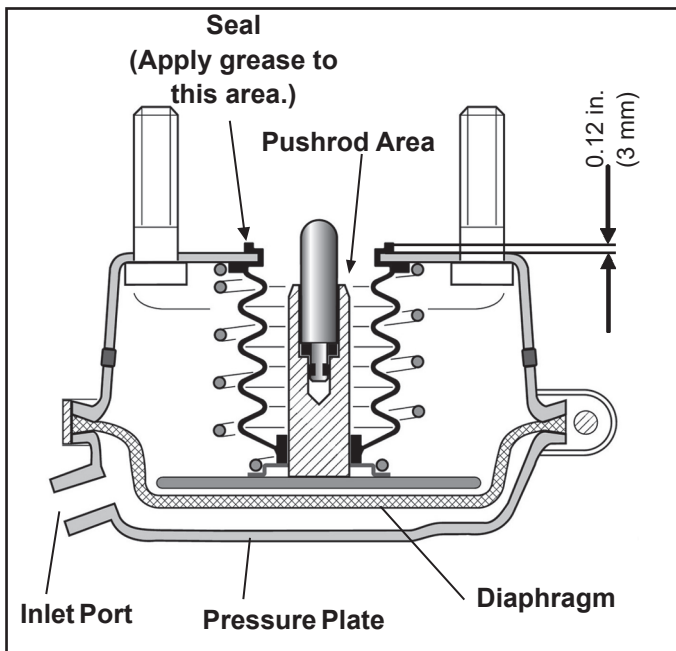

Figure 5 - Seal Inspection & Grease Application

1. Apply pressure to the service port of the chamber. Do not exceed 10 psi.
2. To prevent the pushrod from retracting and to prevent the internal boot/seal from twisting, clamp the pushrod in place with vise grips at the pushrod opening of the replacement service brake chamber. Be sure to protect the seal and spherical end of the pushrod before clamping with vise grips.
3. Release the air pressure from the service port.
4. Remove the clamp band and hardware from the service brake chamber.
5. Position the clamp band and inlet port by rotating the pressure plate of the brake chamber as needed.
6. Make sure that the diaphragm is properly aligned and seated.
7. Reinstall the clamp band and hardware. Tighten the nut to 20-30 ft-lbs. (28-40 Nm).
8. Reapply the air pressure (10 psi) to the service port, remove the vise grips and then release the air pressure.
9. Inspect the clamp ring and hardware for proper seating.
10. Apply 120 psi of air pressure to the service port and check for leakage by applying a soap solution to the clamp ring area. No leakage is permitted.
11. Remove the air pressure from the service port of the brake chamber.

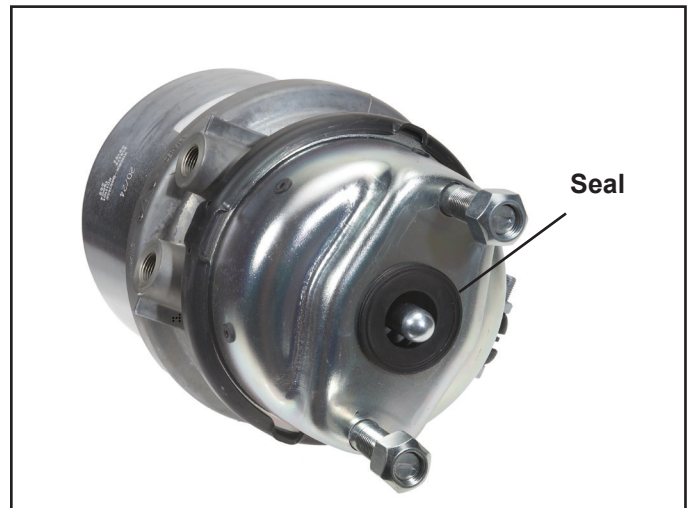

Figure 6 - Piston-Style Spring Brake Chamber

Service Brake Chamber Installation

NOTE: New brake chambers have drain plugs installed (see Figure 3, arrows A). After installation, remove whichever plug is at the lowest position to ensure all water will drain from the brake chamber. Be sure that all other drain holes remain plugged. The drain hole must be aligned downward (or within $\pm 30^\circ$) when installed on the vehicle.

Before installing the new brake chamber, the mounting flange (see Figure 4, arrow C) must be cleaned and inspected. The spherical cup in the lever must be greased with white grease (Part No. II14525 or II32868).

CAUTION: Do not use grease containing molybdenum disulfate.

See Figure 5. Clean and dry the seal, as well as the pushrod area. Apply white grease (Part No. II14525 or II32868) to the seal area.

CAUTION: Do not use brake chambers with seals with a thickness less than 0.12 in. (3 mm). Use only brake chambers which are recommended by the vehicle manufacturer.

1. Install the brake chamber using new self-locking nuts (EN ISO 10513). Tighten alternately both nuts step by step up to a final torque of 133 ± 7 ft-lbs. (180 ± 10 Nm).
2. Re-connect the air hose and be sure that the hose is not twisted or in contact with moving vehicle components. The air hose routing must allow for full caliper travel. Test for leakage and check the brake operation and effectiveness before returning the vehicle to service.

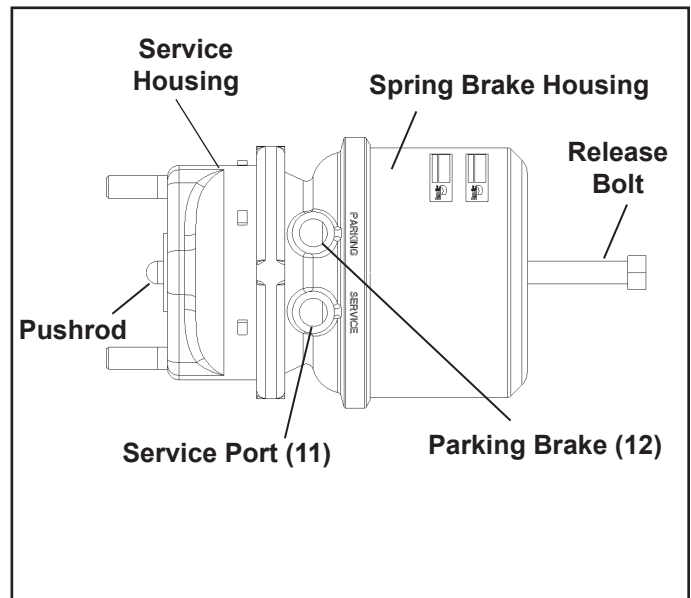

Figure 7 – Spring Brake Shown In The Caged Position

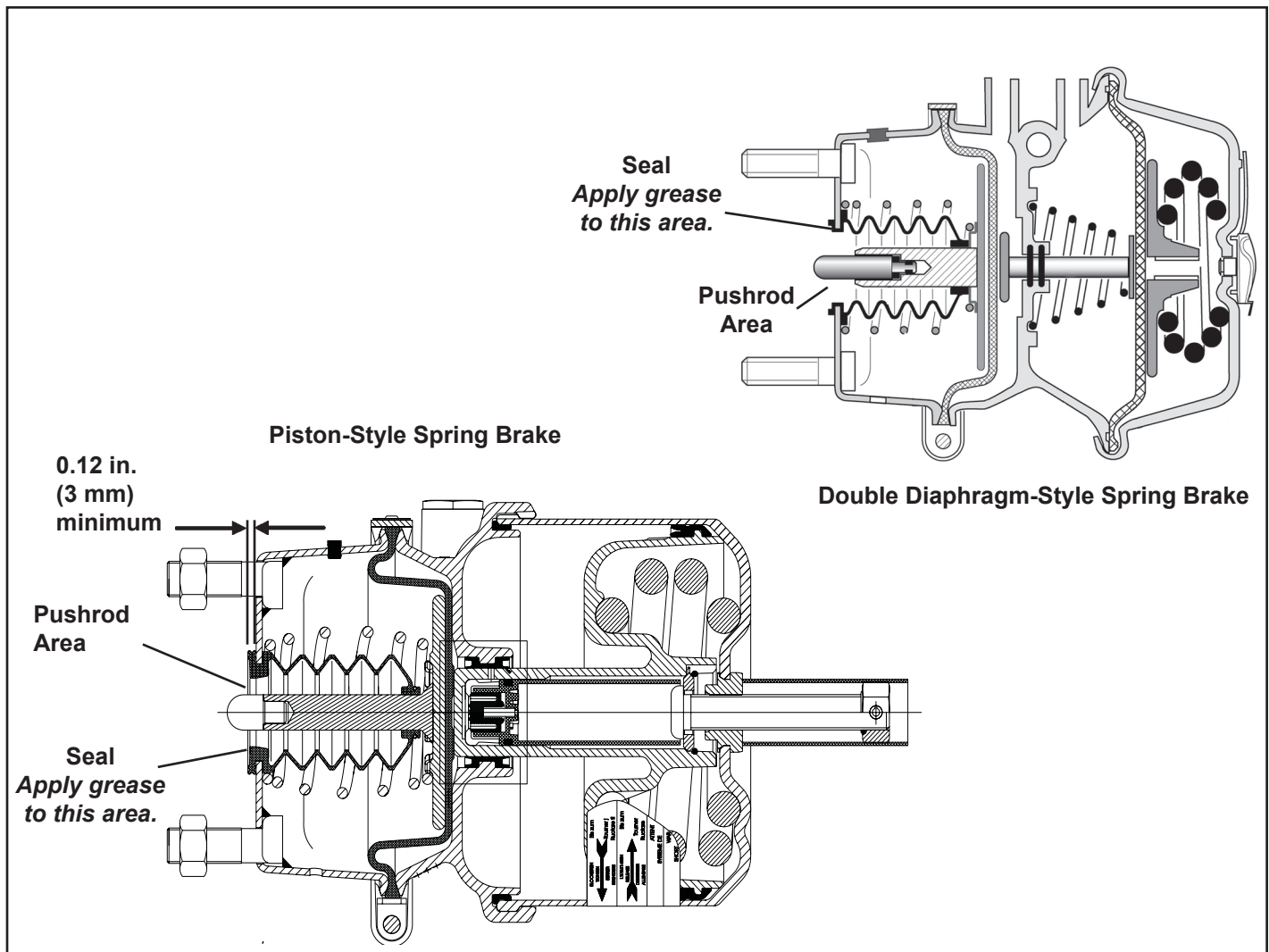

Figure 8 – Spring Brake Chamber Seal Inspection & Grease Application

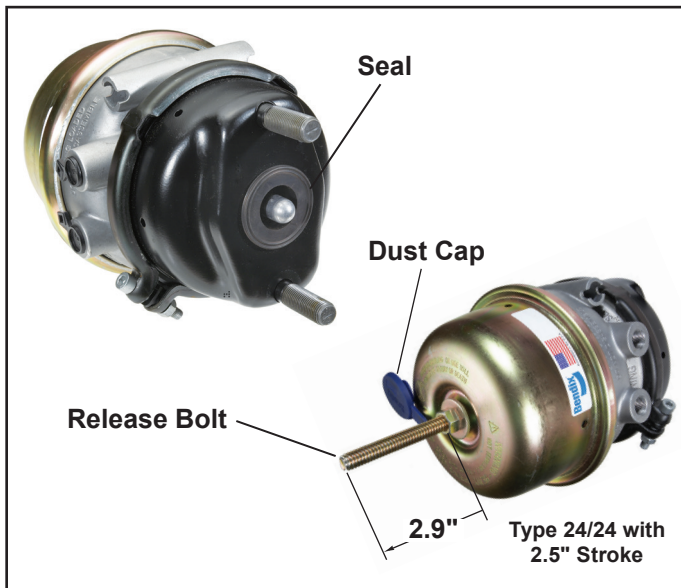

Figure 9 – Double Diaphragm-Style Spring Brake Shown In The Caged Position

Spring Brake Chamber Removal

WARNING:

Do not mechanically release (cage) the spring if there is any structural damage to the brake. Caging the spring in such a chamber may cause serious injury or death. Replace the complete spring brake assembly.

CAUTION: Follow all standard safety procedures on page 2. Be familiar with all spring brake recommended safety practices.

Bendix® Piston-Style Spring Brakes

As always, follow all recommended safety procedures when performing any service on your vehicle.

1. The release bolt cannot be removed from the parking brake (integral release bolt design).
2. The nut is permanently attached to the release bolt.
3. DO NOT USE an impact wrench to rotate the caging bolt nut.
4. Please refer to service data sheet SD-23-7541 for complete service instructions for Air Disc Brakes products from Knorr Bremse, Bendix, and Bendix Spicer Foundation Brake.

Caging the Piston-Style Spring Brake Chamber (Release Park Brake)

1. The Bendix style of piston spring brake does not include a dust plug or weather seal, so removal is not necessary.
2. Connect a regulated air line to the parking brake port (12) of the actuator (if not connected previously).
3. Gradually supply 100 psi of air pressure to the parking brake port (12) of the actuator.

4. To manually cage the piston-style spring brake, turn the release bolt nut counterclockwise with a hand wrench. The maximum releasing torque should not exceed 25.8 lb-ft (35 Nm). Verify that the service side pushrod is retracting during the process and that the release bolt of the spring brake is extending from inside the spring brake housing. **(DO NOT USE A HIGH SPEED AND/OR POWER DRIVEN IMPACT WRENCH.)**
5. Rotate the release bolt counterclockwise until a slight resistance is encountered. Proper caging will be complete when a slight resistance is felt after turning the release bolt nut. The release bolt should be extended as shown in Figure 7. **(DO NOT OVER TORQUE RELEASE BOLT. OVER TORQUING CAN CAUSE SPRING BRAKE DAMAGE.)**
6. Release the air pressure from the parking port (port 12) after caging and prior to any disassembly or removal from vehicle.

Bendix® Double Diaphragm-Style Spring Brakes

As always, follow all recommended safety procedures when performing any service on your vehicle.

1. DO NOT USE an impact wrench to rotate the caging bolt nut.
2. Please refer to service data sheet SD-23-7541 for complete service instructions for Air Disc Brake products from Knorr-Bremse, Bendix, and Bendix Spicer Foundation Brake.

Caging the Double Diaphragm-Style Spring Brake Chamber (Release Park Brake)

1. Remove the dust plug or weather seal from the keyhole located at the rear center of the spring brake chamber. See Figure 9.
2. Remove the release tool assembly from the side pocket of the spring brake chamber.
3. Insert the release tool (T-bolt) through the release tool keyhole and into the power spring piston plate.
4. Turn the release tool 1/4 turn clockwise.
5. Pull on the release tool to ensure the T-section is properly seated in the power spring piston plate.
6. Assemble release tool washer and nut onto release bolt and finger tighten only. If caging is being done manually - it is recommended that some type of lube be applied to the release bolt threads prior to tightening to prevent galling or stripping.
7. To manually cage the spring brake, turn release tool nut clockwise with hand wrench. The maximum releasing torque should not exceed 50 ft-lbs (67.8 Nm). Verify that the service side pushrod is retracting during the process and that the release bolt is extending from inside the spring brake housing. **(DO NOT USE A HIGH SPEED AND/OR POWER DRIVEN IMPACT WRENCH.)**

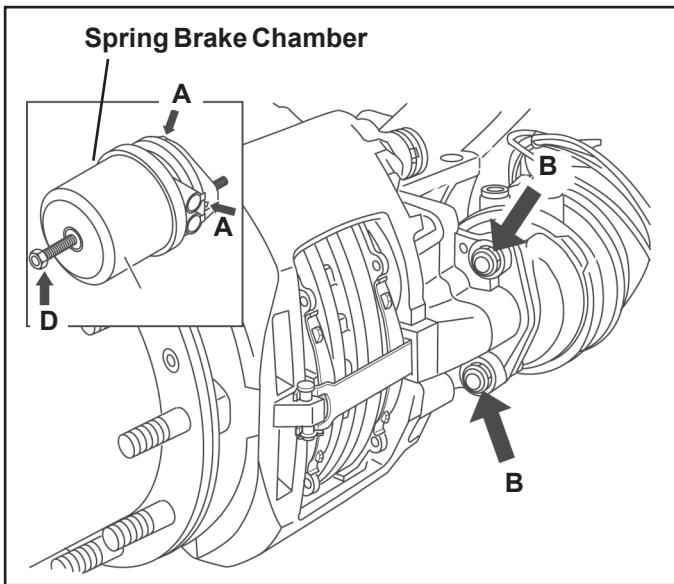

Figure 10 – Spring Brake Installation



Figure 12 – Bendix® Piston-Style Spring Brake Port Connections

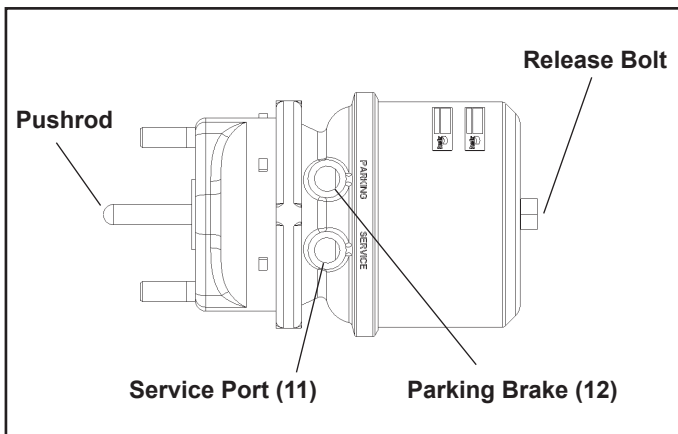

Figure 11 – Spring Brake Shown In The Un-Caged (Released) Position

8. Rotate the release bolt nut clockwise until a slight resistance is encountered. Proper caging will be complete when a slight resistance is felt after turning the release bolt nut. The release bolt should be extended as shown in Figure 9. **(DO NOT OVER TORQUE RELEASE BOLT. OVER TORQUING CAN CAUSE SPRING BRAKE DAMAGE.)**
9. This procedure will be made much easier if air pressure (100-120 psi; 6.6-8.0 bar) is used to collapse the power spring before turning the release bolt nut with a hand wrench.
10. Release the air pressure from the parking port (port 12) after caging and prior to any disassembly or removal from vehicle.

IMPORTANT: To ensure the power spring is fully caged, the extended release tool length should measure 2.9 inches as shown in Figure 9.

Spring Brake Chamber Removal

1. With spring brake chamber caged and all air pressure drained from the air brake system, disconnect the air hose from the spring brake chamber.
2. While supporting the spring brake chamber in position, remove and discard brake chamber mounting nuts (see Figure 10, arrows B). Remove the spring brake.

Spring Brake Chamber Clocking

CAUTION: The replacement spring brake must be caged to perform this procedure!

1. Apply pressure to the service port of the chamber. Do not exceed 10 psi.
2. To prevent the pushrod from retracting and to prevent the internal boot/seal from twisting, clamp the pushrod in place with vise grips at the pushrod opening of the replacement service brake chamber. Be sure to protect the seal and spherical end of the pushrod before clamping with vise grips.
3. Release the air pressure from the service port.
4. Remove the clamp and hardware from the service chamber side of the spring brake chamber.
5. Position the mounting studs, ports, clamp band, and drains by turning the service chamber or piggyback unit as needed.
6. Ensure that the service diaphragm is aligned and properly seated.
7. Reinstall the clamp rings and hardware. Tighten the nut to 20-30 ft-lbs. (28-40 Nm).
8. Inspect the clamp ring and hardware for proper seating.
9. Apply pressure to the service port of the chamber. Do not exceed 10 psi.
10. Remove the vise grips from the pushrod.

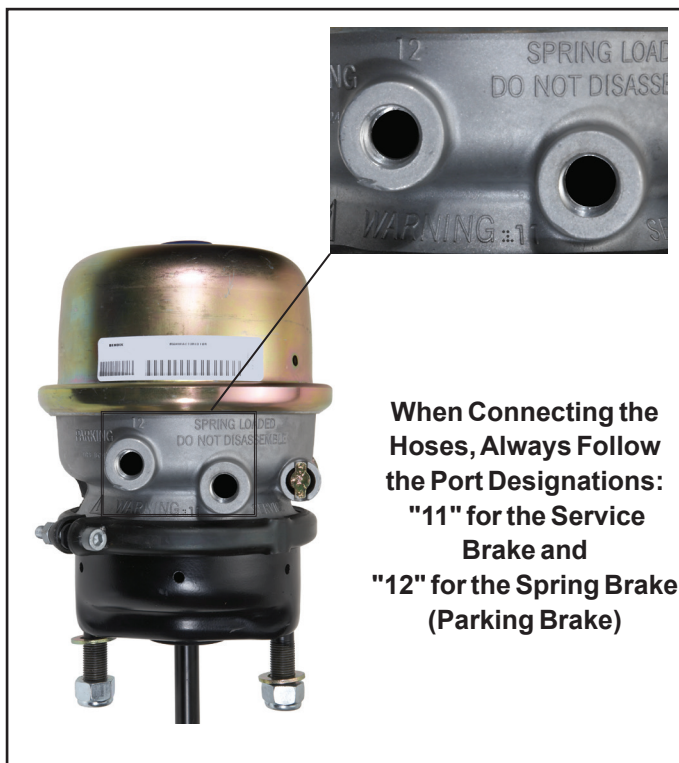

When Connecting the Hoses, Always Follow the Port Designations: "11" for the Service Brake and "12" for the Spring Brake (Parking Brake)

Figure 13 – Bendix® Double Diaphragm-Style Spring Brake Port Connections

11. Apply 120 PSI of air pressure to the service port and check for leakage by applying a soap solution to the clamp ring area. No leakage is permitted.
12. Remove the air pressure from the service side of the spring brake chamber.

Spring Brake Chamber Installation

NOTE: New spring brake chambers have drain plugs installed (see Figure 10, arrows A). After installation, remove whichever plug is at the lowest position to ensure all water will drain from the spring brake chamber. Be sure that all other drain holes remain plugged. The drain hole must be aligned downwards (or within $\pm 30^\circ$) when installed on the vehicle.

Before installing the new spring brake chamber, the mounting flange (see Figure 4, arrow C) must be cleaned and inspected. The spherical cup in the lever must be greased with white grease (Part No. II14525 or II32868).

CAUTION: Do not use grease containing molybdenum disulfate.

See Figure 8. Clean and dry the seal, as well as the pushrod area. Apply white grease (Part No. II14525 or II32868) to the seal area.

CAUTION: Do not use brake chambers with seals with a thickness less than 0.12 in. (3 mm). Use only chambers which are recommended by the vehicle manufacturer.

1. Install the brake chamber using new self-locking nuts (EN ISO 10513). Tighten alternately both the nuts step by step up to a final torque of 133 ± 7 ft. lbs. (180 ± 10 Nm).
2. Re-connect the air hose and be sure that the hose is not twisted or in contact with moving vehicle components. The air hose routing must allow for full caliper travel.

NOTE: Early spring brake chambers were manufactured with metric ports. If the chamber being replaced/serviced has metric threads, an adapter may be required to facilitate the connection of the air hoses to the spring brake chamber.

Test for leakage and check the brake operation and effectiveness before returning the vehicle to service. Note that for spring brake service chambers the ports are indicated by:

"11" Service Brake Port and "12" Spring Brake Port

Un-Caging the Piston-Style Spring Brake Chamber (Apply Park Brake)

1. Connect a regulated air line to the parking brake port (12) of the chamber (if not connected previously). See Figure 12.
2. Gradually supply 100 psi of air pressure to the parking brake port (12) of the actuator.
3. Turn the release bolt nut counter clockwise with a hand wrench. **(DO NOT USE A HIGH SPEED OR POWER DRIVEN IMPACT WRENCH.)**
4. Continue turning the release bolt nut clockwise until it seats against the spring brake housing. Torque the release bolt nut to 14.75-51.63 lb-ft (20-70 Nm). This will ensure that no water or contaminants are ingested by the spring brake and reduce corrosion of the release bolt.
5. The release bolt and pushrod should be in the position shown in Figure 11.
6. With hands clear of moving parts, slowly release the air pressure to the parking brake port (12). Be sure to exercise caution to prevent pinching of fingers.

Un-Caging the Double Diaphragm-Style Spring Brake Chamber (Apply Park Brake)

1. Connect a regulated air line to the parking brake port (12) of the chamber (if not connected previously). See Figure 13.
2. Gradually supply 100 psi of air pressure to the parking brake port (12) of the actuator.
3. Turn the release bolt nut counterclockwise with a hand wrench. **(DO NOT USE A HIGH SPEED OR POWER DRIVEN IMPACT WRENCH.)**
4. Continue to turn the release bolt nut until the caging tool is loose. Remove caging bolt nut and washer.

5. Push the release bolt tool in, turn the release bolt 1/4 turn counterclockwise and remove it from the pressure plate key hole.
6. With hands clear of moving parts, slowly release the air pressure to the parking brake port (12). Be sure to exercise caution to prevent pinching of fingers.
7. Place caging bolt in spring brake tool holder with T-head down and seated in slot. Install washer and nut on exposed threads (this allows the washer to protect the holder cavity and caging bolt from corrosive elements).
8. Torque the caging bolt nut to 10-15 lb-ft (14-20 Nm).
9. Mount the dust plug/weather seal in the keyhole located at the rear center of the spring brake chamber. Lift all around the edge of the dust plug/weather seal to be sure it is firmly seated.

IMPORTANT: Always re-install tethered dust plug/weather seal in spring brake caging tool key hole. Failure to do so will result in corrosion and foreign material ingestion through the key hole which may void the warranty. Do not use excessive force when installing the dust plug/weather seal. Extreme force may cause damage and make it unusable.

Replacement dust plugs or weather seals can be purchased from your local Bendix Distributor.

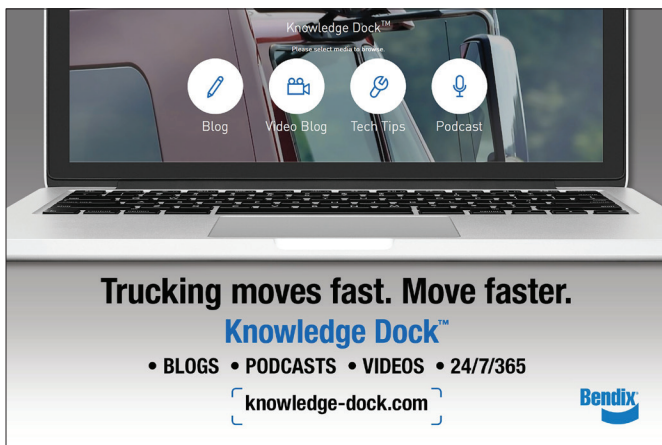

Trucking moves fast. Move faster.
Knowledge Dock™
• BLOGS • PODCASTS • VIDEOS • 24/7/365
[knowledge-dock.com] 



Log-on and Learn from the Best

On-line training that's available when you are —24/7/365.
Visit brake-school.com.