

RELEASE NUMBER	REV LTR	REVISION DESCRIPTION	BY	DATE	APPD
P36908-68	-	INITIAL RELEASE	NAH	03/14/11	SAS

1

TORQUE FASTENERS TO 22 ± 3 N·m (16 ± 2 LB·FT).

2

MATE LOCATING TABS TO SQUARE CUTOUTS IN STEP SUPPORTS (REF MOD 779).

ITEM NUMBER	D22-69263-002	<b>DAIMLER</b>		Daimler Trucks North America	
DESCRIPTION	INSTL-P3 FAIR,STEP TREAD,FIXED,RH				
THE INFORMATION CONTAINED HEREIN IS PROPRIETARY DATA, AND IS NOT FOR DISSEMINATION OR DISCLOSURE, IN WHOLE OR IN PART, FOR ANY PURPOSE OTHER THAN THAT FOR WHICH IT IS SUBMITTED, EXCEPT AS AUTHORIZED IN WRITING BY DAIMLER TRUCKS NORTH AMERICA LLC (DTNA)					
ITEM NUMBER	D22-69263-001	MATERIAL APPROVAL	DATE	UNLESS OTHERWISE NOTED, DIMENSIONS AND TOLERANCES ARE DEFINED ACCORDING TO ASME Y14.5M-1994, WITH EXCEPTION PER DTNA 09ENG-WI037	
DESCRIPTION	INSTL-P3 FAIR,STEP TREAD,HINGED,RH	N/A	N/A		
ITEM NUMBER	D22-69263-000	DRAWN BY	DATE		
DESCRIPTION	INSTL-P3 FAIR,STEP TREAD,HINGED,LH	N.HILL	03/14/11		
		CHECKED BY	DATE	THIRD ANGLE PROJECTION	
		S.SARGEANT	03/14/11		
		RESPONSIBLE ENGINEER	DATE		
		M.MOYES	03/14/11	UNITS OF MEASURE MM	
		APPROVED BY	DATE		
		S.SARGEANT	03/14/11		
DESCRIPTION <b>INSTL-P3 FAIR,STEP TREAD</b>					
SUPPLEMENTAL DESCRIPTION 782A1					
ITEM/DRAWING NUMBER <b>D22-69263</b>			REVISION LETTER -		PAGE 1 of 4

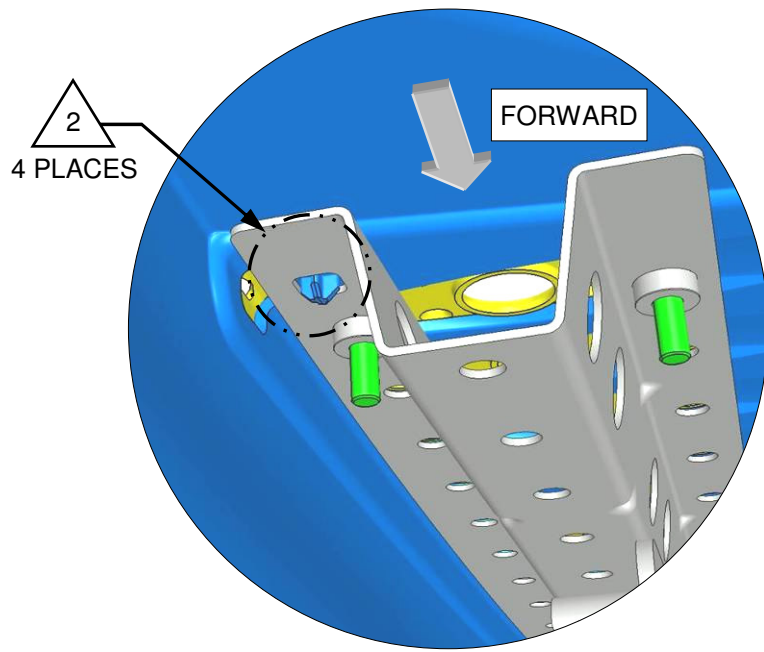
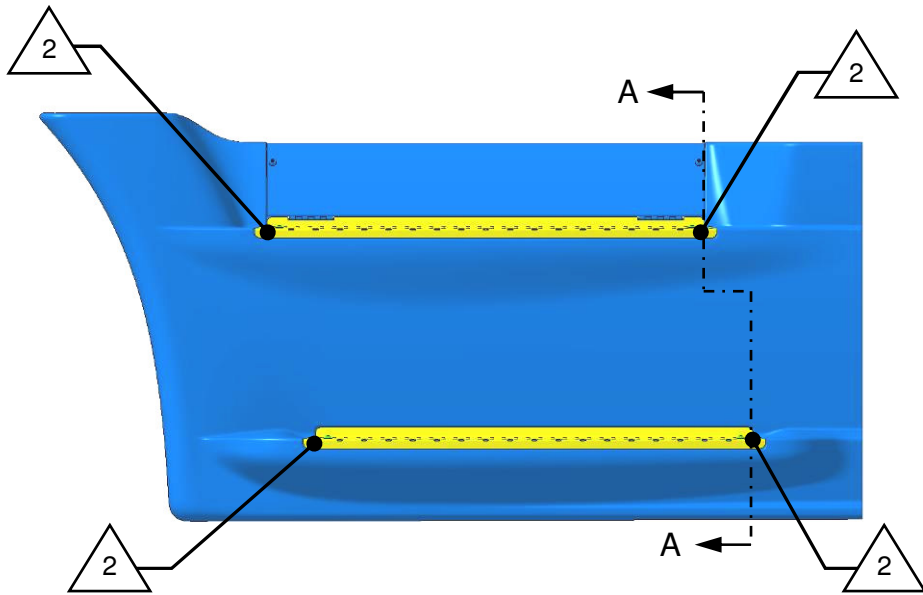

VIEW B

LOCATING FEATURES

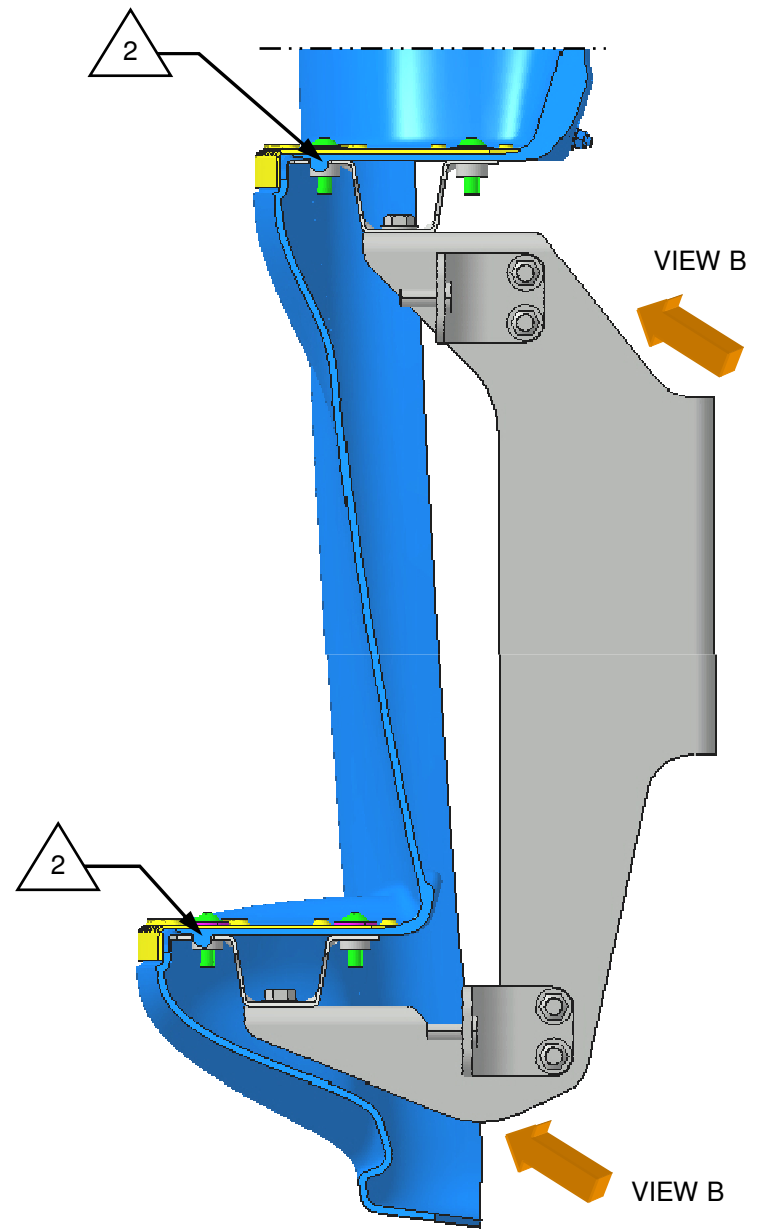

SECTION A-A

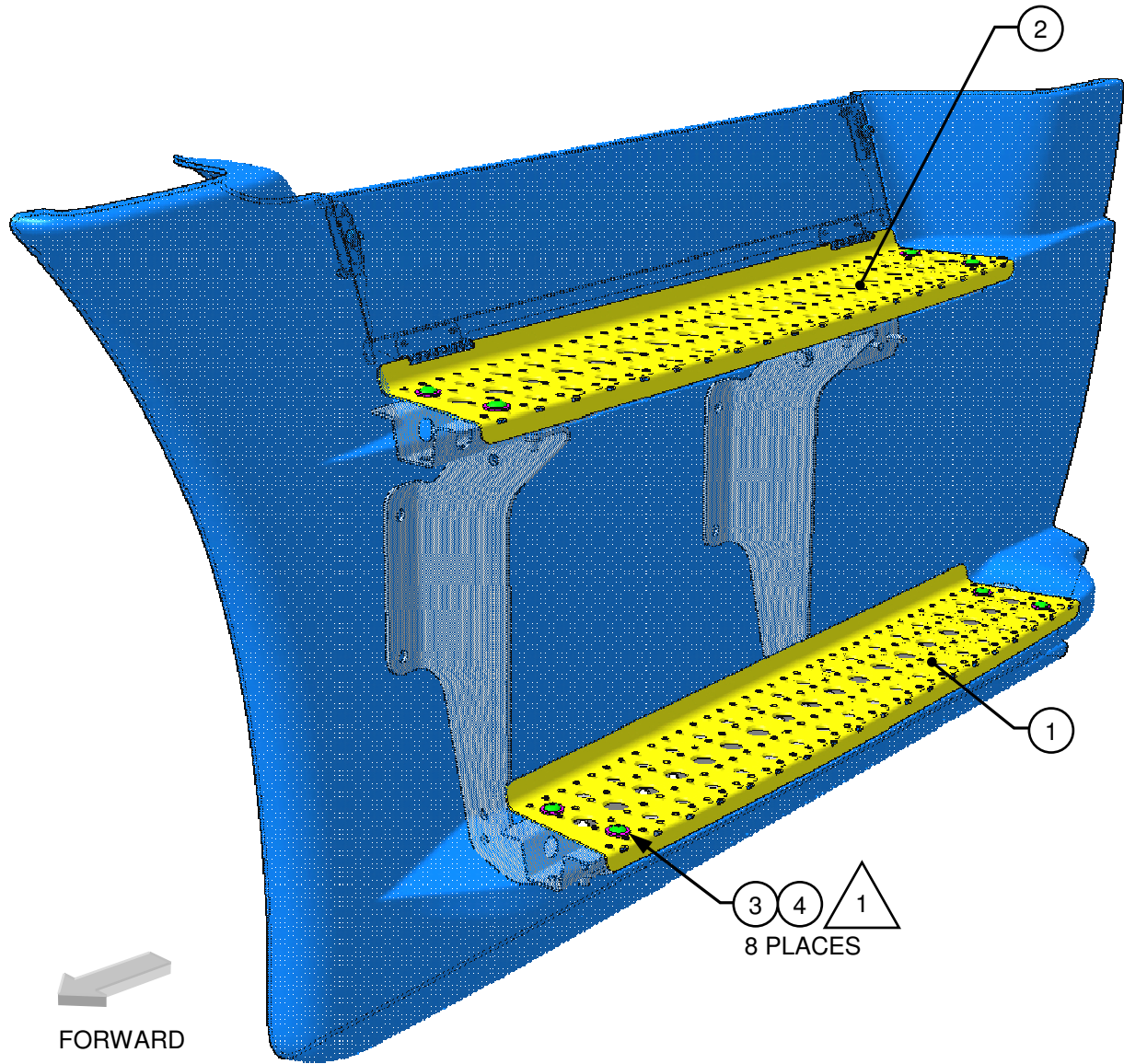

FORWARD

-000 LH SHOWN

-001 RH OPPOSITE

ITEM/DRAWING NUMBER	REVISION LETTER	PAGE
<b>D22-69263</b>	-	3 of 4

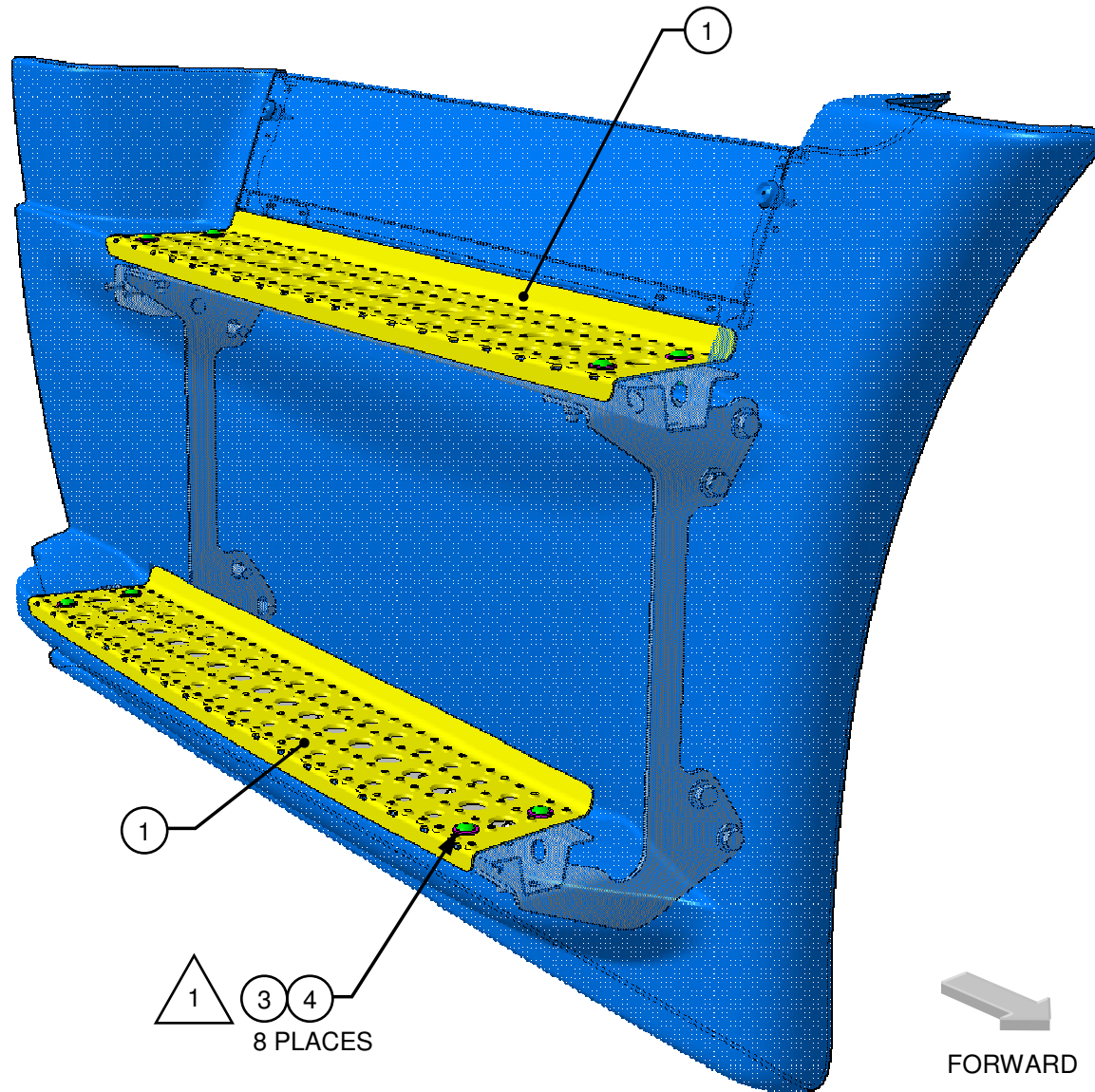

-002 RH SHOWN