

RELEASE NUMBER	REV LTR	REVISION DESCRIPTION	BY	DATE	APPD
P21CAB-17	D	REMASTERED IN PPT & ADDED NOTE 4	MST	05/08/2023	GLH

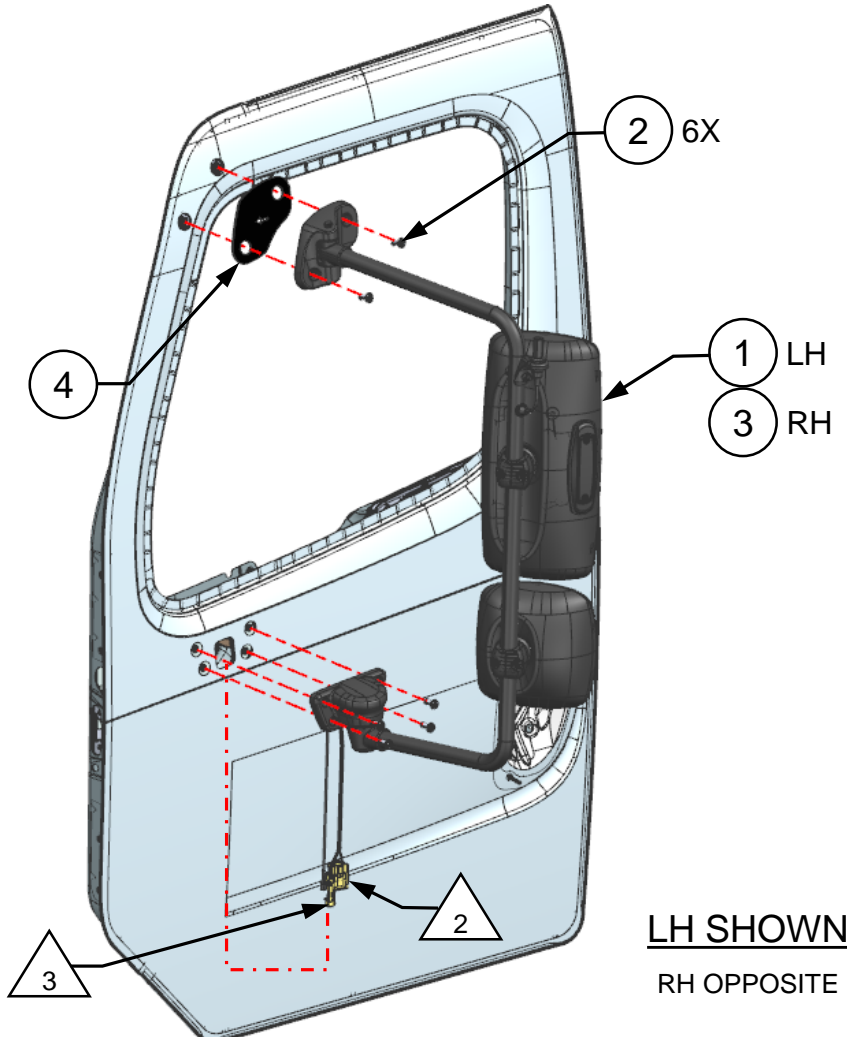

LH SHOWN
RH OPPOSITE

1. TORQUE FASTENERS TO 10-14 Nm
2. CONNECT 2-PIN OR 8-PIN CONNECTOR WHEN PRESENT
3. CONNECT ANTENNA CABLE WHEN PRESENT
4. VISUALLY INSPECT MIRROR FOR LOOSENESS ON DOOR. APPLY FORE/AFT LOAD ON MIRROR ARM AND OBSERVE MOUNTING BRACKETS FOR RELATIVE MOTION TO MOUNTING SCREWS AND/OR DOOR. RE-TORQUE LOOSE FASTENERS AS NEEDED. SPEC TORQUE MAY NEED TO BE EXCEEDED IN ORDER TO RUN SCREWS TO FINAL TORQUE DUE TO PATCH LOCK MATERIAL ON SCREWS.

(D)

ITEM NUMBER D22-52241-000 DESCRIPTION INSTL-MIRROR, PRIMARY, M2	DAIMLER		Daimler Trucks North America	
	THE INFORMATION CONTAINED HEREIN IS PROPRIETARY DATA, AND IS NOT FOR DISSEMINATION OR DISCLOSURE, IN WHOLE OR IN PART, FOR ANY PURPOSE OTHER THAN THAT FOR WHICH IT IS SUBMITTED, EXCEPT AS AUTHORIZED IN WRITING BY DAIMLER TRUCKS NORTH AMERICA LLC (DTNA)			
	MATERIAL APPROVAL N/A		DATE N/A	
	DRAWN BY M.TURNAUER		DATE 05/08/23	
	CHECKED BY M.TURNAUER		DATE 03/20/23	
RESPONSIBLE ENGINEER M.TURNAUER		DATE 03/20/23		
APPROVED BY G.HOILAND		DATE 03/20/23		
DESCRIPTION INSTL-MIRROR, PRIMARY, M2		THIRD ANGLE PROJECTION		UNITS OF MEASURE MM
SUPPLEMENTAL DESCRIPTION 744A1 M2/M2 PLUS SERIES				
ITEM/DRAWING NUMBER D22-52241		REVISION LETTER D	PAGE 1 of 1	