



RELEASE NUMBER	REV LTR	REVISION DESCRIPTION	BY	DATE	APPD
P24407-47	-	INITIAL RELEASE	RJH	06/13/07	TKC
P33690-99	A	MODIFIED NOTE 2 (SEE SHEET 2)	RJH	10/04/07	PCB
P43394-01	B	B1:ADDED -004 & SHEET 6	R3P	11/28/11	PCB
		B2:ADDED -005 & SHEET 7			
P53227-01	C	C1:ADDED -006 & SHEET 8	K2L	06/15/16	GLH

C1

ITEM NUMBER	D18-61814-006			Daimler Trucks North America	
DESCRIPTION	INSTL-AIR RSTR IND-INTK MTD, P3			<small>THE INFORMATION CONTAINED HEREIN IS PROPRIETARY DATA, AND IS NOT FOR DISSEMINATION OR DISCLOSURE, IN WHOLE OR IN PART, FOR ANY PURPOSE OTHER THAN THAT FOR WHICH IT IS SUBMITTED, EXCEPT AS AUTHORIZED IN WRITING BY DAIMLER TRUCKS NORTH AMERICA LLC (DTNA)</small>	
ITEM NUMBER	D18-61814-005	MATERIAL APPROVAL	N/A	DATE	N/A
DESCRIPTION	INSTL-AIR RSTR IND-INTK MTD, P3	DRAWN BY	R.HERNANDEZ	DATE	05/23/07
ITEM NUMBER	D18-61814-004	CHECKED BY	T.CHU	DATE	05/23/07
DESCRIPTION	INSTL-AIR RSTR IND-INTK MTD, P3	RESPONSIBLE ENGINEER	R.HERNANDEZ	DATE	05/23/07
ITEM NUMBER	D18-61814-003	APPROVED BY	T.CHU	DATE	05/29/07
DESCRIPTION	INSTL-AIR RSTR IND-DSH MTD, BRT,P3	<small>UNLESS OTHERWISE NOTED, DIMENSIONS AND TOLERANCES ARE DEFINED ACCORDING TO ASME Y14.5M-1994, WITH EXCEPTION PER DTNA 09ENG-WI037</small>			
ITEM NUMBER	D18-61814-002			UNITS OF MEASURE MM	
DESCRIPTION	INSTL-AIR RSTR IND-DSH MTD, BLK,P3	DESCRIPTION INSTL-AIR RESTRICTOR P3			
ITEM NUMBER	D18-61814-001	SUPPLEMENTAL DESCRIPTION 198A1			
DESCRIPTION	INSTL-AIR RSTR IND-INTK MTD, P3	ITEM/DRAWING NUMBER	D18-61814		REVISION LETTER C
				PAGE	1 of 8



ADAPTER FILTER ELEMENT MUST BE INSTALLED AWAY FROM AIR FILTER OUTLET.



ROUTE AND CLAMP TUBING (ITEM 3) ALONG FRONT WALL HARNESS THROUGH FRONT WALL TO GAUGE. TUBING NOT TO INTERFERE WITH AIR CLEANER MAINTENANCE.



RECOMMENDED SCREW TORQUE: 4 – 6 Lb-in (.45 - .68 Nm)

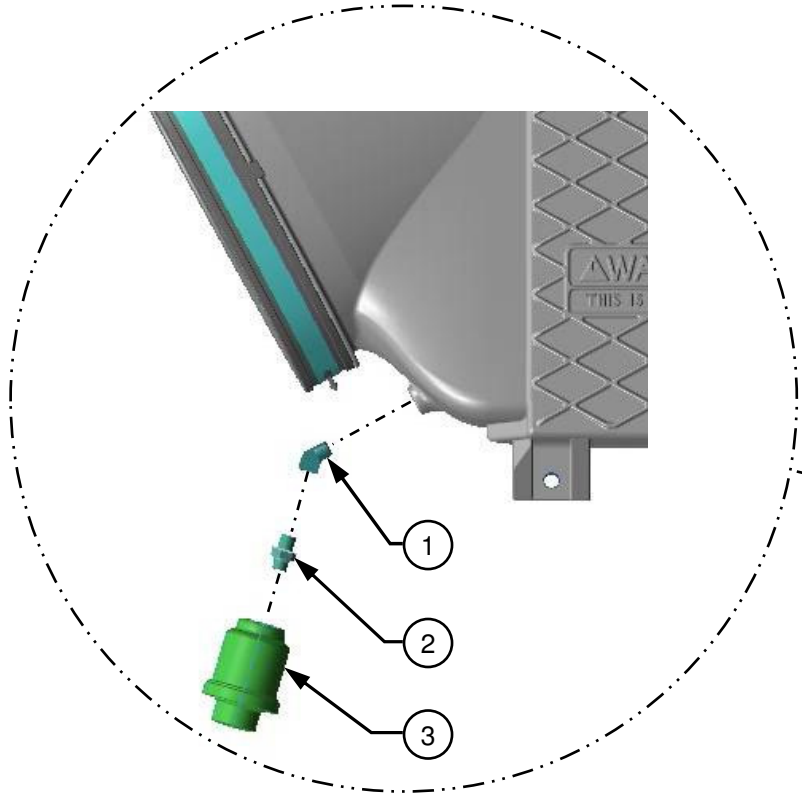

TOP VIEW
EXPLODED

AIR INTAKE
REF MOD 190

FORWARD

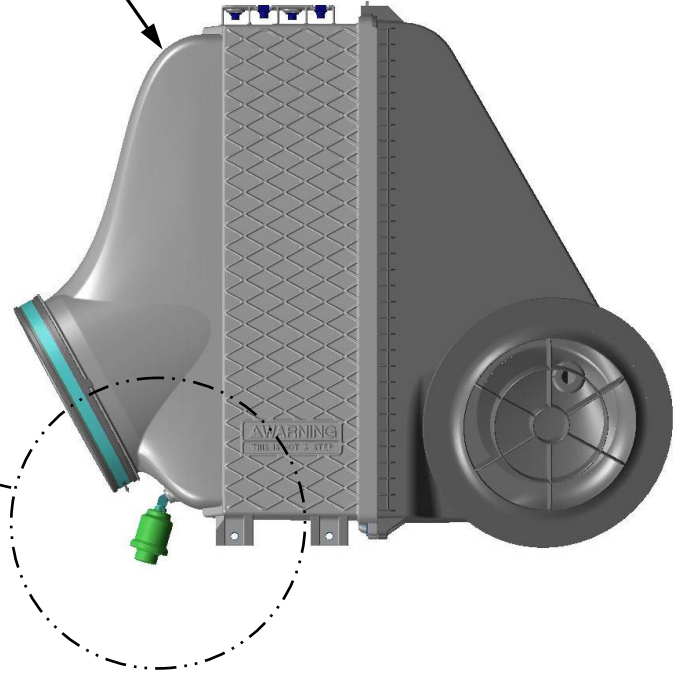

TOP VIEW
ASSEMBLED

INSTL -000

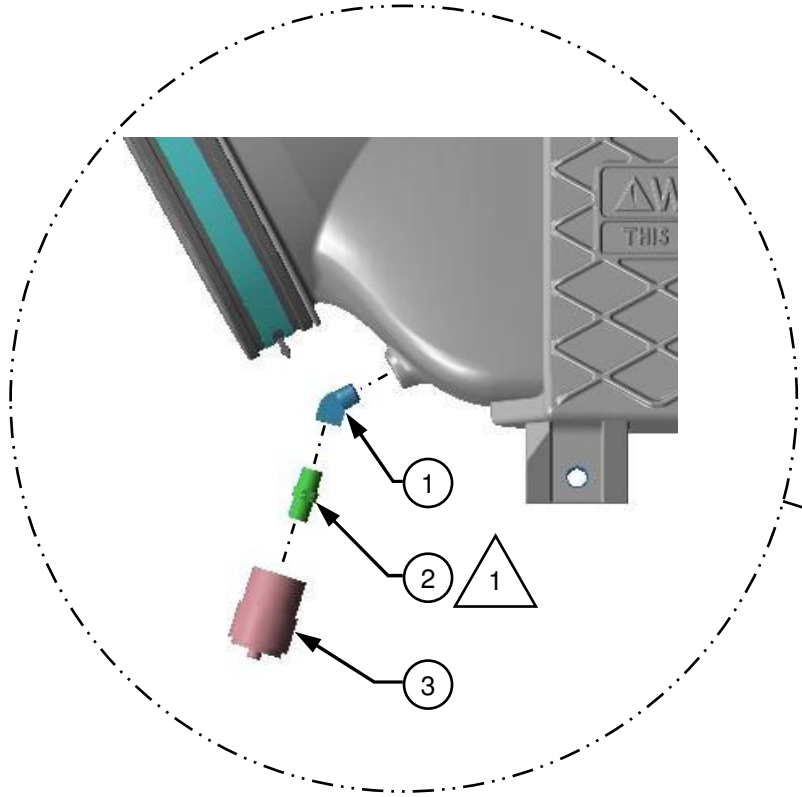

TOP VIEW
EXPLODED

AIR INTAKE
REF MOD 190

FORWARD

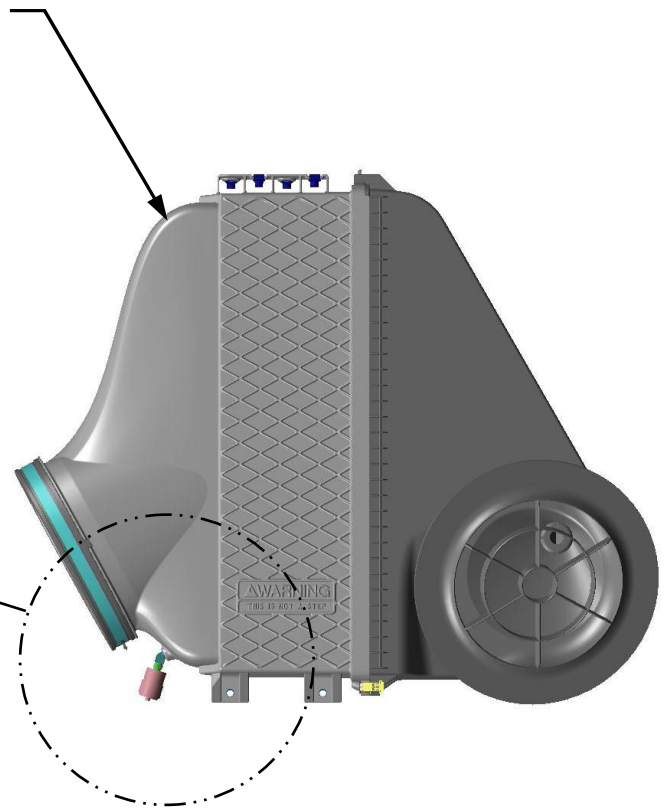

TOP VIEW
ASSEMBLED

INSTL -001

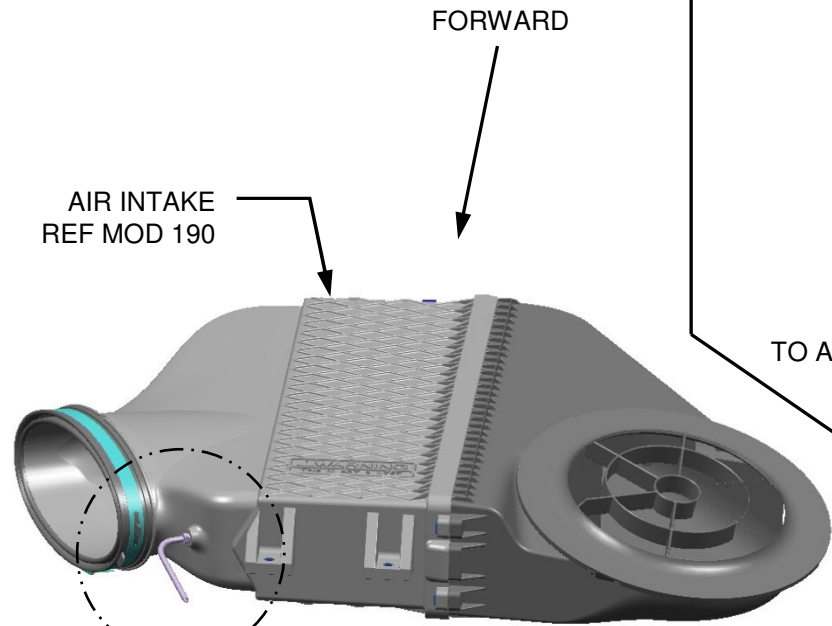

INSTL -002 / -003
ENGINE COMPARTMENT
SIDE

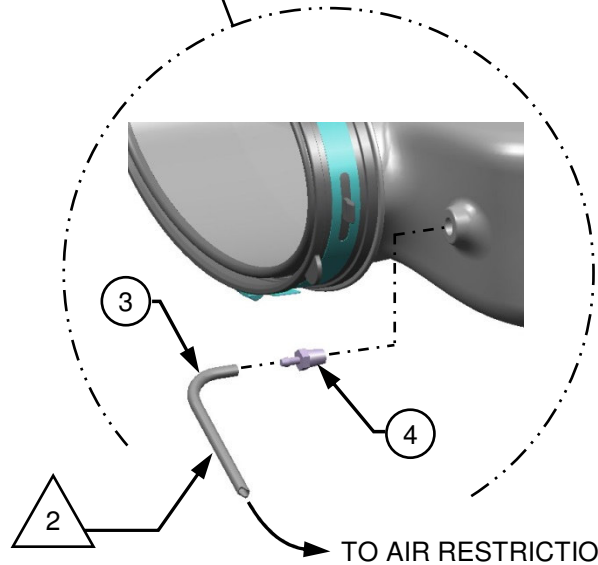

TO AIR FILTER

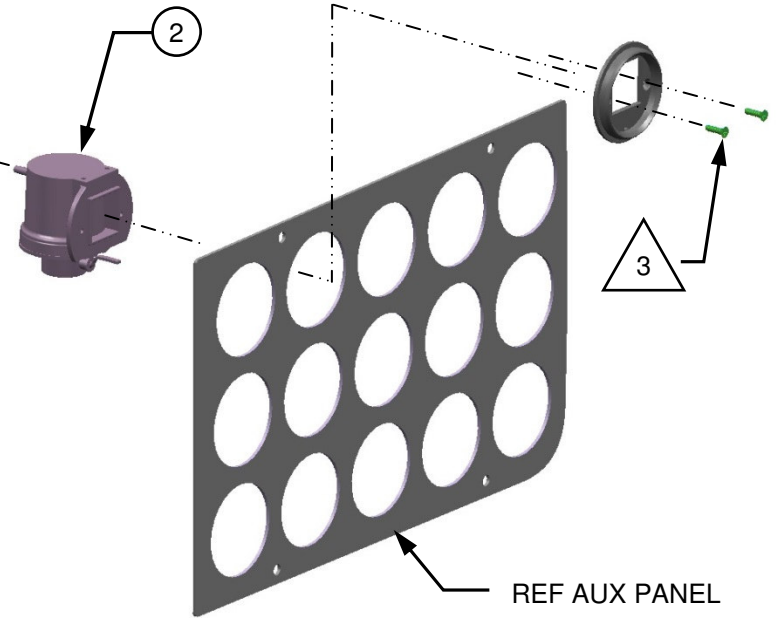

FORWARD

INSTL -002 / -003
CAB SIDE

AIR INTAKE
REF MOD 190

FORWARD

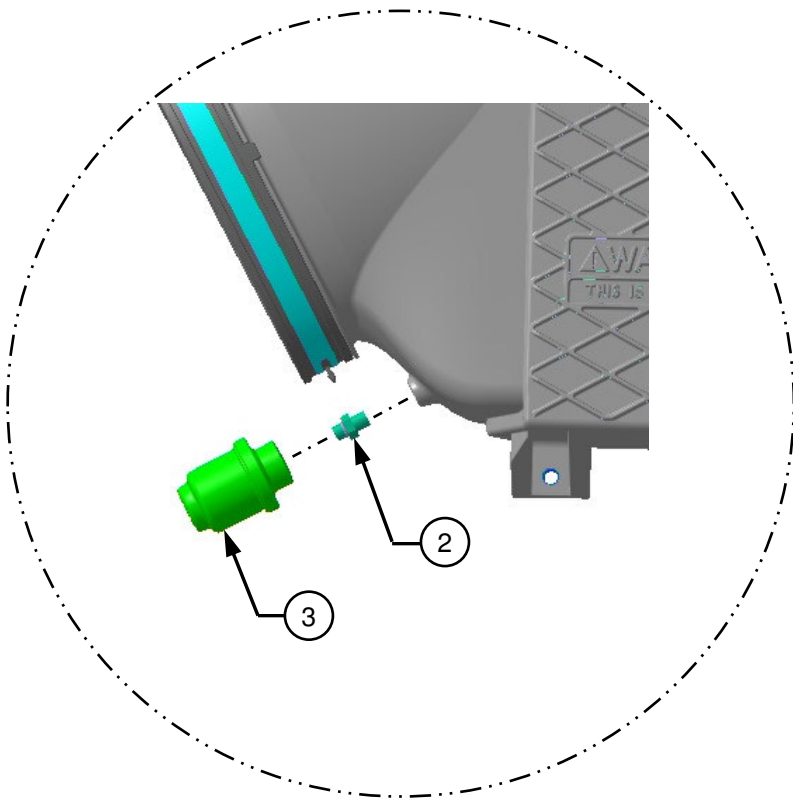

TOP VIEW
EXPLODED

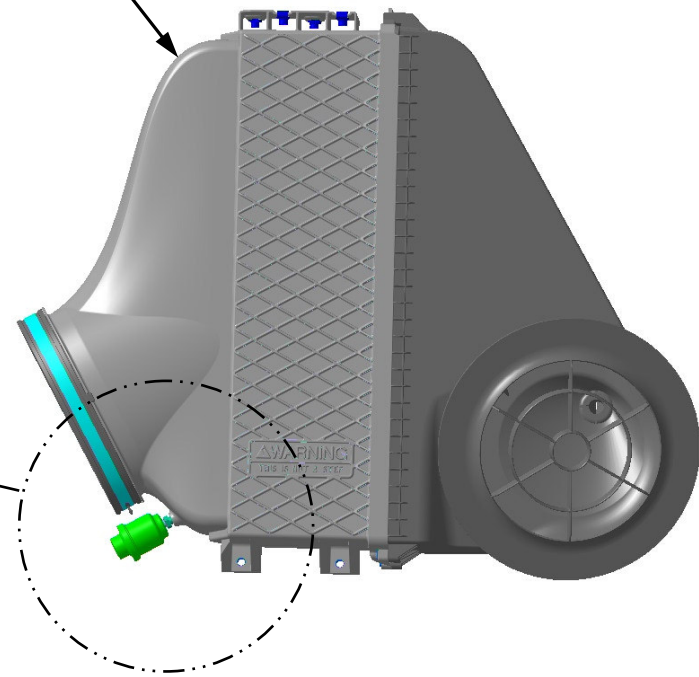

TOP VIEW
ASSEMBLED

INSTL -004

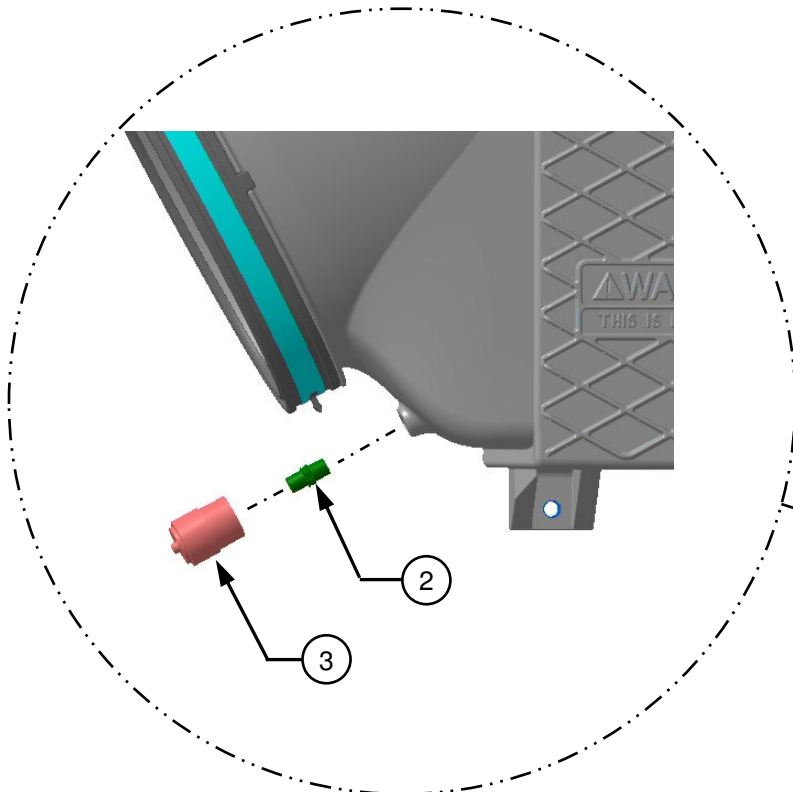

TOP VIEW
EXPLODED

AIR INTAKE
REF MOD 190

FORWARD
↓

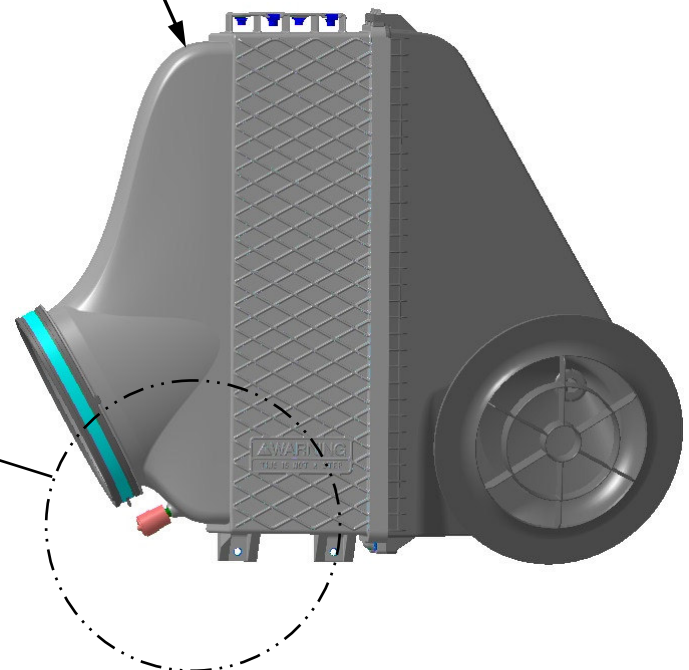

TOP VIEW
ASSEMBLED

INSTL -005

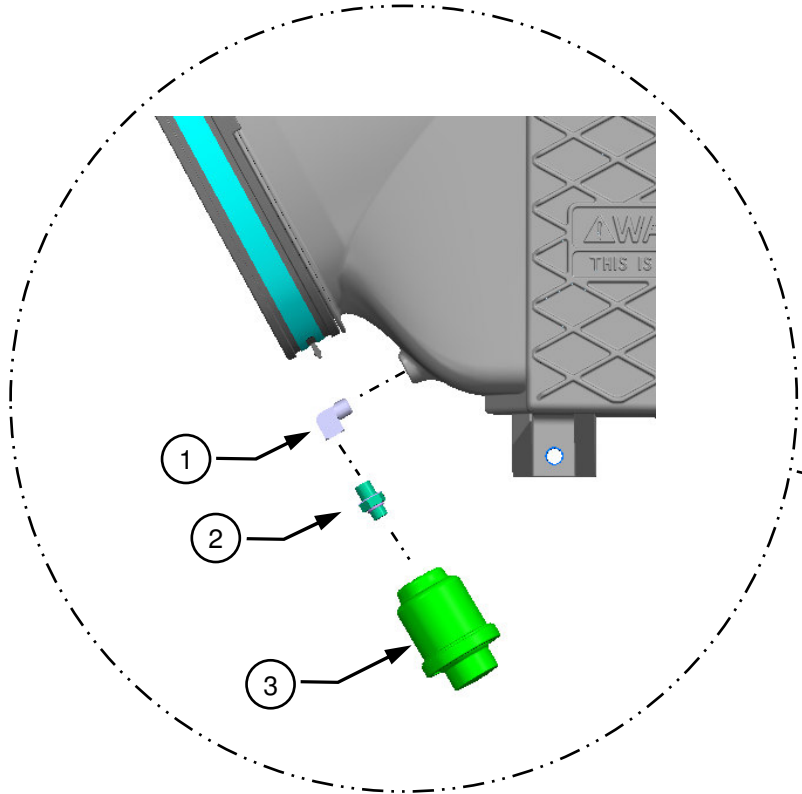

TOP VIEW
EXPLODED

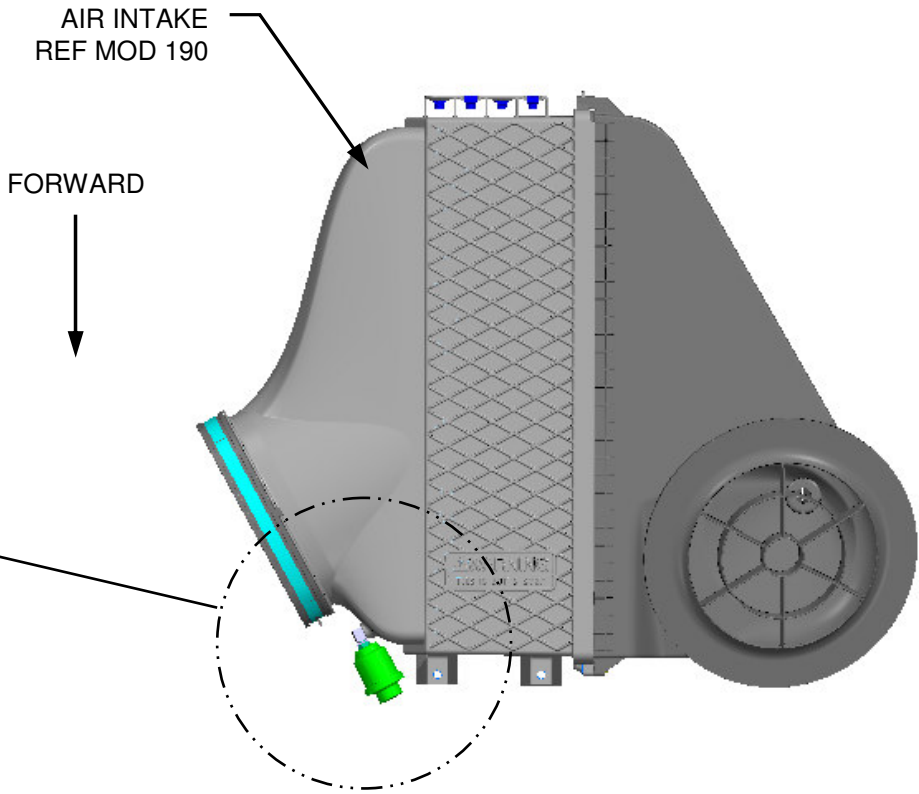

TOP VIEW
ASSEMBLED

INSTL -006

C1