

RELEASE NUMBER	REV LTR	REVISION DESCRIPTION	BY	DATE	APPD
P38242-03	D	1. MIGRATED TO POWER POINT FORMAT 2. REMOVED ITEM 5	JED	11/17/09	B1K
P38392-03	E	1. REPLACED ITEM 651/003 2. MODIFIED NOTE 2, WAS 7-9 FT-LBF	JED	11/20/10	BK1
P54204-01	F	1. MOD 651 CHANGED TO 66Z	MPD	09/29/16	ATO
P18CAB-X5	G	1. REVISED NOTE 2	T9M	09/27/21	J5N

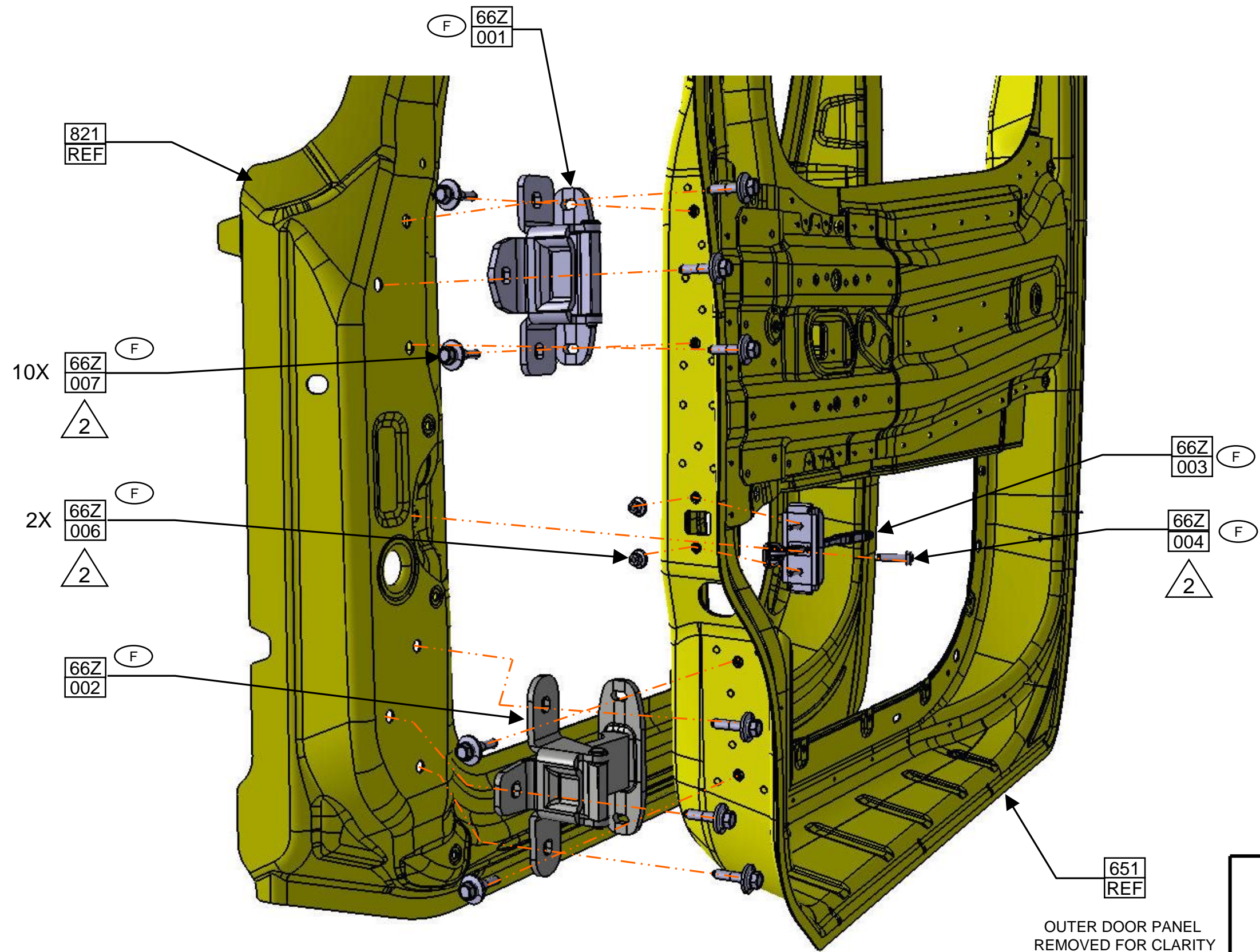

-000 SHOWN / -001 RH OPPOSITE

OUTER DOOR PANEL REMOVED FOR CLARITY

- LOAD CHECK ASSEMBLY THROUGH OPENING ON DOOR ASSEMBLY (MOD 651). INSURE PROPER ORIENTATION OF CHECK ARM BRACKET FOR INSTALLATION TO DOOR OPENING PANEL (MOD 821).
- M8 SCREWS AND M6 NUTS: FASTENER TORQUE CALLED OUT IN BILL OF MATERIAL. (G)

ITEM NUMBER D18-53648-001		DESCRIPTION INSTALL-DOOR,HINGE,CHECK,P3,RH		ITEM NUMBER D18-53648-000		DESCRIPTION INSTALL-DOOR,HINGE,CHECK,P3,LH				Daimler Trucks North America	
<small>THE INFORMATION CONTAINED HEREIN IS PROPRIETARY DATA, AND IS NOT FOR DISSEMINATION OR DISCLOSURE, IN WHOLE OR IN PART, FOR ANY PURPOSE OTHER THAN THAT FOR WHICH IT IS SUBMITTED, EXCEPT AS AUTHORIZED IN WRITING BY DAIMLER TRUCKS NORTH AMERICA LLC (DTNA)</small>											
MATERIAL APPROVAL B.KASHIWAGI		DATE 11/17/09		DRAWN BY J.DENDIUK		DATE 11/17/09		<small>UNLESS OTHERWISE NOTED, DIMENSIONS AND TOLERANCES ARE DEFINED ACCORDING TO ASME Y14.5M-1994, WITH EXCEPTION PER DTNA 09ENG-WI037</small>			
CHECKED BY J.KOCH		DATE 11/17/09		RESPONSIBLE ENGINEER J.KOCH		DATE 11/17/09		<small>THIRD ANGLE PROJECTION</small>		<small>UNITS OF MEASURE MM</small>	
APPROVED BY B.KASHIWAGI		DATE 11/17/09		<b>INSTALL-DOOR,HINGE,CHECK,P3</b>							
<small>SUPPLEMENTAL DESCRIPTION</small>											
<small>ITEM/DRAWING NUMBER</small>											
<b>D18-53648</b>								<small>REVISION LETTER</small> <b>G</b>		<small>PAGE</small> 1 of 1	