

RELEASE NUMBER	REV LTR	REVISION DESCRIPTION	BY	DATE	APPD
P53299-02	-	INITIAL RELEASE	J10	05/04/16	BTM

ITEM NUMBER D15-28592-000	DESCRIPTION INSTL-XM, DAYCAB, BOC	DAIMLER		Daimler Trucks North America	
		THE INFORMATION CONTAINED HEREIN IS PROPRIETARY DATA, AND IS NOT FOR DISSEMINATION OR DISCLOSURE, IN WHOLE OR IN PART, FOR ANY PURPOSE OTHER THAN THAT FOR WHICH IT IS SUBMITTED, EXCEPT AS AUTHORIZED IN WRITING BY DAIMLER TRUCKS NORTH AMERICA LLC (DTNA)			
		MATERIAL APPROVAL N/A	DATE N/A	UNLESS OTHERWISE NOTED, DIMENSIONS AND TOLERANCES ARE DEFINED ACCORDING TO ASME Y14.5M-1994, WITH EXCEPTION PER DTNA 09ENG-WI037	
		DRAWN BY J.SHEA	DATE 05/04/16		
		CHECKED BY B.MORRISS	DATE 05/04/16		
		RESPONSIBLE ENGINEER B.OUTEN	DATE 05/04/16		
APPROVED BY B.MORRISS	DATE 05/04/16	THIRD ANGLE PROJECTION		UNITS OF MEASURE MM	
DESCRIPTION INSTL-XM, DAYCAB, BOC					
SUPPLEMENTAL DESCRIPTION 561A1					
ITEM/DRAWING NUMBER D15-28592		REVISION LETTER -		PAGE 1 of 2	

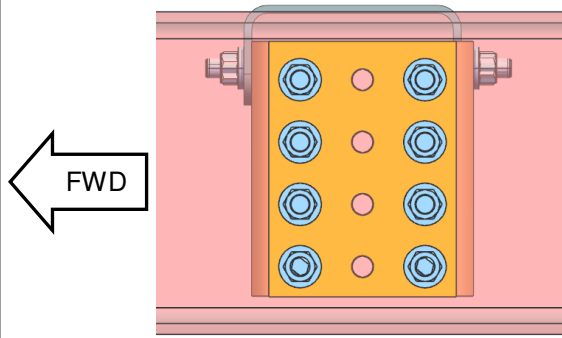

VIEW A

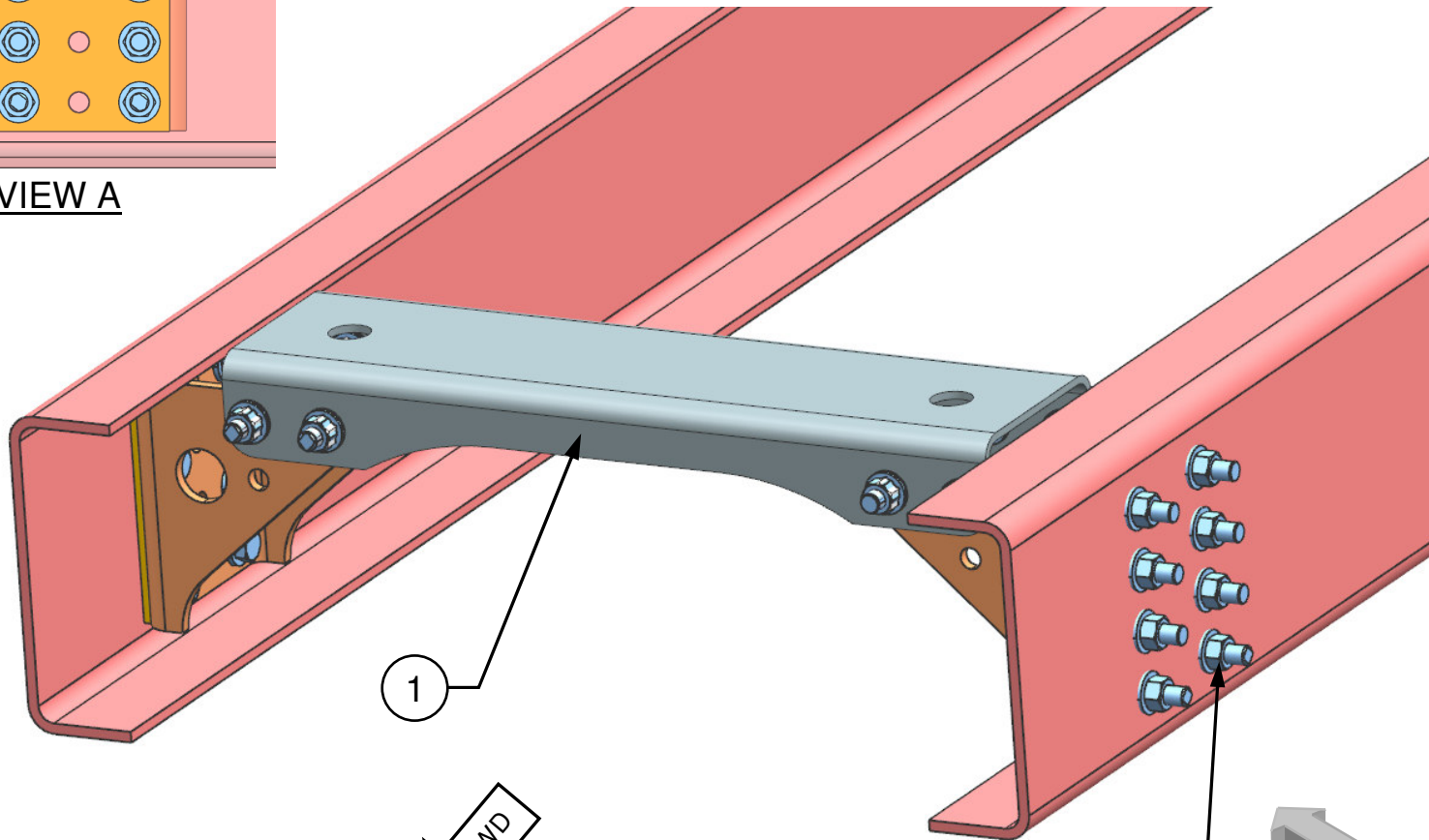

1

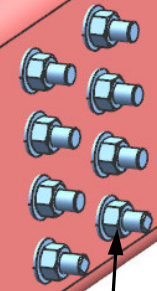

- 16X (2)
- 16X (3)
- 32X (4)

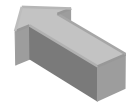

VIEW A