

RELEASE NUMBER	REV LTR	REVISION DESCRIPTION	BY	DATE	APPD
P37711-07	-	INITIAL RELEASE	MBS	05/17/10	SCB
PLIA01-Y7	A	REVISED NOTE 1 TORQUE FROM 20.	D2E	07/13/16	EAT
P53811-02	B	ADDED PG 3, -001	ARR	08/03/16	EAT

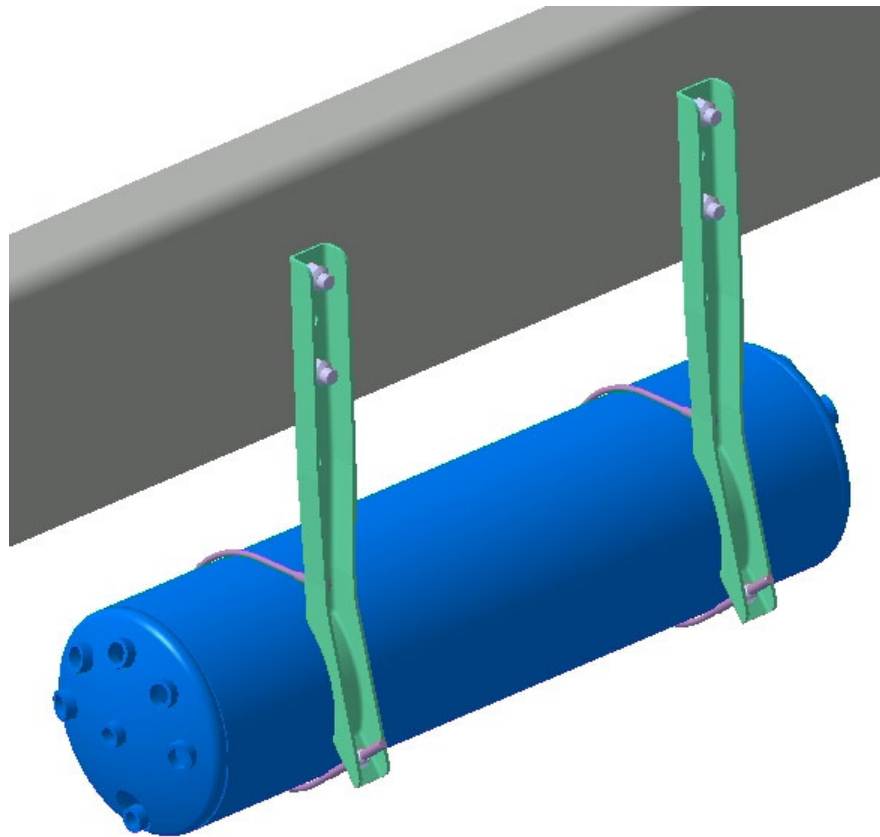

- A**
1. TORQUE NUT, ITEM 4, TO 8.1 ± 2.7 NM (6±2 FT-LBS.). HOLD END TO PREVENT CABLE FROM TWISTING.
 2. END CAP WELD SEAMS MUST NOT CONTACT THE MOUNTING BRACKETS.
 3. CENTER AIR TANK IN BRACKETS UNLESS OFFSET NEEDED FOR CLEARANCE.
 4. DO NOT USE HUCKBOLT FASTENERS.

ITEM NUMBER D12-24634-001	DESCRIPTION INSTL-AIR TANK,9IN,BELOW,3 BRKTS	ITEM NUMBER D12-24634-000	DESCRIPTION INSTL-AIR TANK,9IN,BELOW	DAIMLER		Daimler Trucks North America	
				THE INFORMATION CONTAINED HEREIN IS PROPRIETARY DATA, AND IS NOT FOR DISSEMINATION OR DISCLOSURE, IN WHOLE OR IN PART, FOR ANY PURPOSE OTHER THAN THAT FOR WHICH IT IS SUBMITTED, EXCEPT AS AUTHORIZED IN WRITING BY DAIMLER TRUCKS NORTH AMERICA LLC (DTNA)			
MATERIAL APPROVAL		DATE					
S.BLAUFUSS		05/17/10					
DRAWN BY		DATE					
B.SWITZER		05/17/10					
CHECKED BY		DATE					
S.BLAUFUSS		05/17/10					
RESPONSIBLE ENGINEER		DATE					
B.SWITZER		05/17/10					
APPROVED BY		DATE					
S.BLAUFUSS		05/17/10					
DESCRIPTION				INSTL-AIR TANK,9IN,BELOW			
SUPPLEMENTAL DESCRIPTION				460A1			
ITEM/DRAWING NUMBER				D12-24634		REVISION LETTER B	
				PAGE		1 of 3	

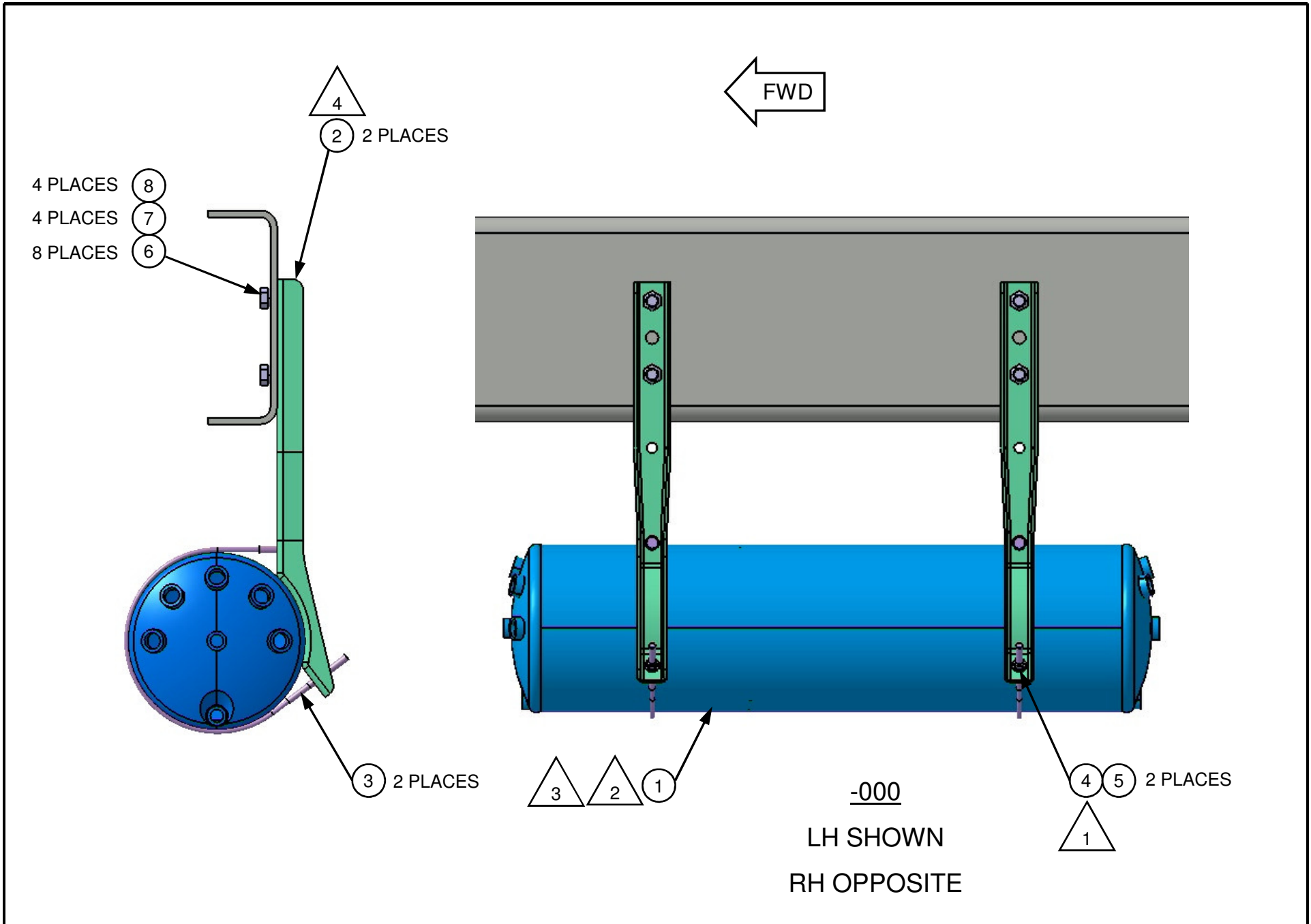

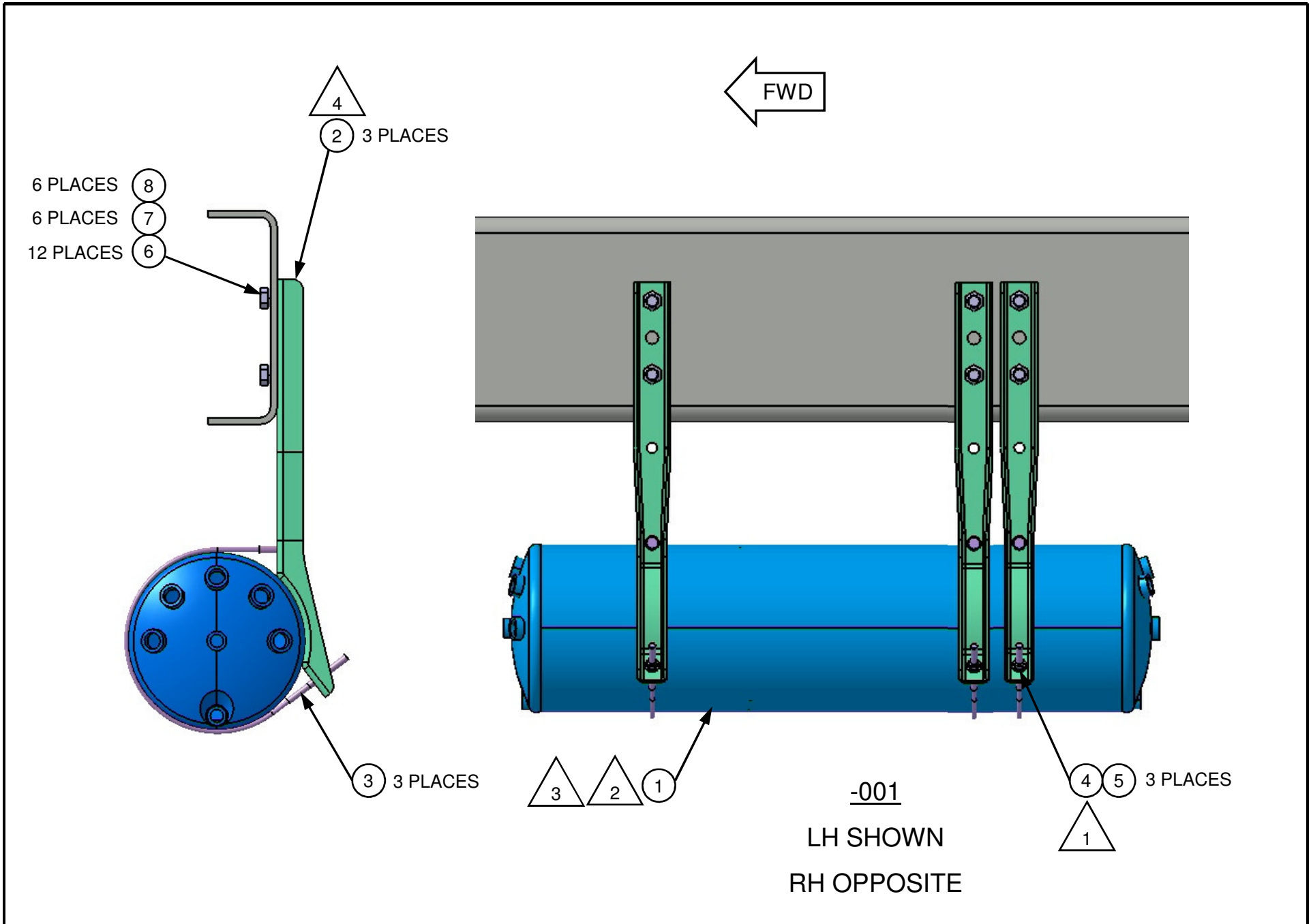

THE INFORMATION CONTAINED HEREIN IS PROPRIETARY DATA, AND IS NOT FOR DISSEMINATION OR DISCLOSURE, IN WHOLE OR IN PART, FOR ANY PURPOSE OTHER THAN THAT FOR WHICH IT IS SUBMITTED, EXCEPT AS AUTHORIZED IN WRITING BY DAIMLER TRUCKS NORTH AMERICA LLC (DTNA)



Daimler Trucks
North America

ITEM/DRAWING NUMBER
D12-24634

REVISION LETTER
B

PAGE
3 of 3