

RELEASE NUMBER	REV LTR	REVISION DESCRIPTION	BY	DATE	APPD
P24693-G6	-	INITIAL RELEASE	IDX	03/13/07	MLC
P24693-N7	A	ADDED PAGE 3, -000 ENG SIDE VIEW, VIEW C; ADDED NOTE 2; REFERENCE SHOPCALL 207888	JTD	08/27/07	CPJ



TORQUE M10 BATTERY CABLE NUTS TO 20 NM +/- 2 (14.75 FT-LBS.), THEN APPLY TORQUE SEAL.



TORQUE M8 SAM MODULE MOUNTING NUTS TO 13.5 NM +/- 2 (10 FT-LBS.).

ITEM NUMBER D06-52856-000		DESCRIPTION INSTL-MUX CTRL,SAM CAB					
				THE INFORMATION CONTAINED HEREIN IS PROPRIETARY DATA, AND IS NOT FOR DISSEMINATION OR DISCLOSURE, IN WHOLE OR IN PART, FOR ANY PURPOSE OTHER THAN THAT FOR WHICH IT IS SUBMITTED, EXCEPT AS AUTHORIZED IN WRITING BY FREIGHTLINER LLC.			
		MATERIAL APPROVAL	DATE	MFG ENG/PURCH AGENT	DATE		
		N/A	N/A	M.HILLIG	09/02/07		
		DRAWN BY	DATE	CHECKED BY	DATE		
		I.DUGOJEVIC	12/07/06	M.CUMMINS	12/07/06		
		RESPONSIBLE ENGINEER	DATE	APPROVED BY	DATE		
		M.CUMMINS	12/07/06	R.BISHEL	12/07/06		
		DESCRIPTION					
		INSTL-MUX CTRL,SAM CAB					
		SUPPLEMENTAL DESCRIPTION					
		32AA1			P3		
		ITEM/DRAWING NUMBER			REVISION LETTER	PAGE	
		D06-52856			A	1	

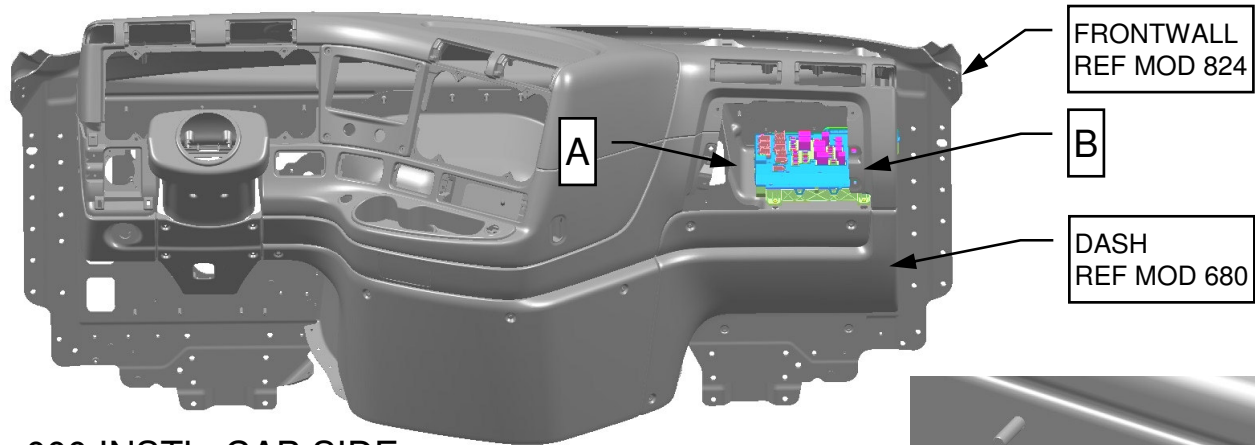

-000 INSTL, CAB SIDE

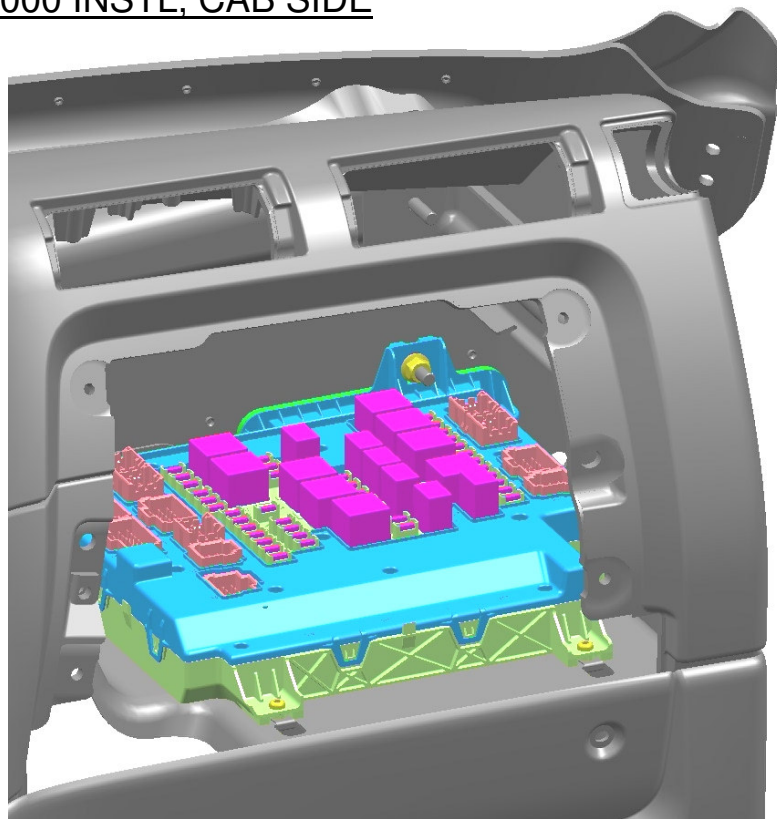

**VIEW A**  
HARDWARE IN PLACE

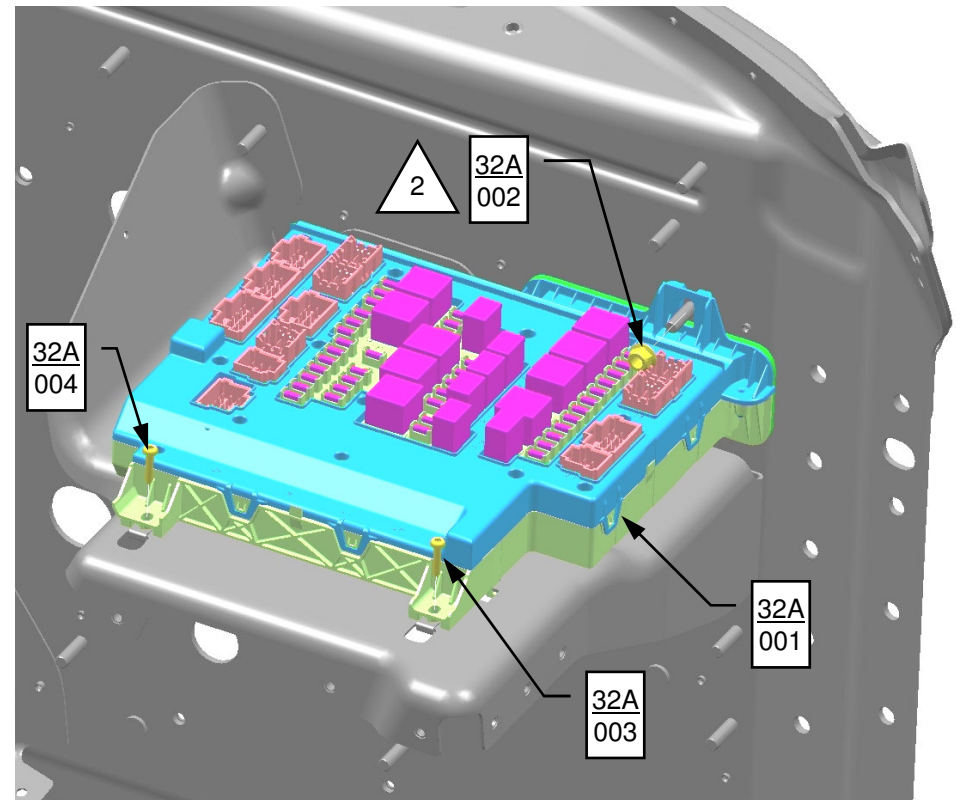

**VIEW B**  
HARDWARE EXPLODED  
SOME PARTS NOT SHOWN FOR CLARITY

ITEM/DRAWING NUMBER <b>D06-52856</b>	REVISION LETTER <b>A</b>	PAGE <b>2</b>
---	-----------------------------	------------------

FRONTWALL  
REF MOD 824

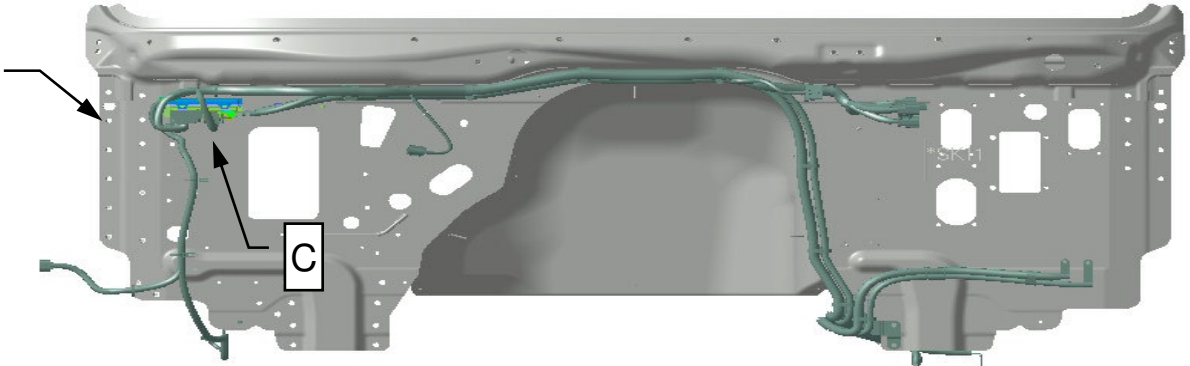

-000 INSTL, ENGINE SIDE

32A  
001

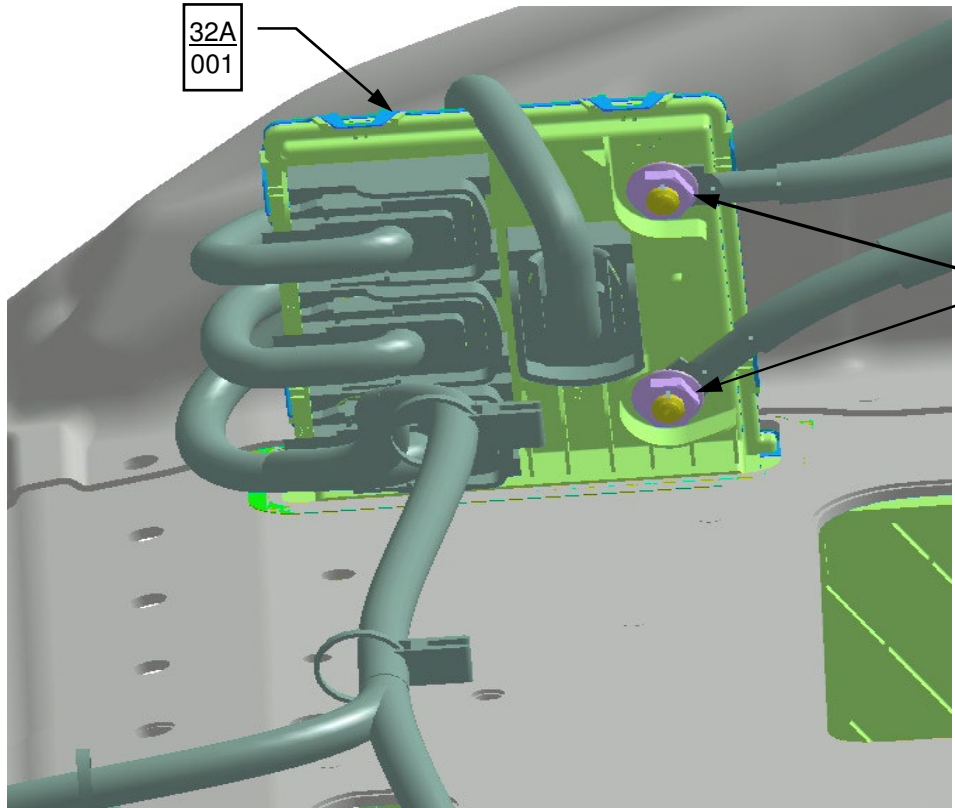

32A  
005



VIEW C  
HARDWARE IN PLACE

ITEM/DRAWING NUMBER	REVISION LETTER	PAGE
D06-52856	A	3