

RELEASE NUMBER	REV LTR	REVISION DESCRIPTION	BY	DATE	APPD
P39371-27	-	INITIAL RELEASE	K8S	06/18/12	FWM
P51849-A1	A	MODIFIED TORQUE SPEC	GRV	10/15/15	JHN
P58556-16	B	ADDED -001	D0B	02/11/20	MID
P58556-34	C	ADDED REFERENCE ITEM 6 FOR -001	D0B	01/25/21	MID

1. TORQUE ALL FASTENERS TO 20 FT. LBS.

DELIVERY MUST CONFORM EXACTLY WITH DRAWING SPECIFICATIONS AND, WHERE REQUIRED BY Q.A., WITH APPROVED Q.A. SAMPLES. ABSOLUTELY NO CHANGES ARE PERMITTED WITHOUT PRIOR APPROVAL BY DTNA. THIS INCLUDES CHANGES TO: SOFTWARE, MATERIALS, INTERNAL COMPONENTS, MANUFACTURING PROCESSES.

ITEM NUMBER D05-31076-001	DESCRIPTION INST-SURGE TANK,RADMTD PTO 43N	ITEM NUMBER D05-31076-000	DESCRIPTION INSTL-SURGE TANK MOUNTING	<b>DAIMLER</b>		Daimler Trucks North America		
				THE INFORMATION CONTAINED HEREIN IS PROPRIETARY DATA, AND IS NOT FOR DISSEMINATION OR DISCLOSURE, IN WHOLE OR IN PART, FOR ANY PURPOSE OTHER THAN THAT FOR WHICH IT IS SUBMITTED, EXCEPT AS AUTHORIZED IN WRITING BY DAIMLER TRUCKS NORTH AMERICA LLC (DTNA)				
				MATERIAL APPROVAL N/A	DATE N/A	UNLESS OTHERWISE NOTED, DIMENSIONS AND TOLERANCES ARE DEFINED ACCORDING TO ASME Y14.5M- 1994, WITH EXCEPTION PER DTNA 09ENG-WI037		
				DRAWN BY K.SHAH	DATE 06/18/12			
				CHECKED BY F.MENCHE	DATE 06/18/12			
				RESPONSIBLE ENGINEER G.DESILETS	DATE 06/18/12			
				APPROVED BY F.MENCHE	DATE 06/18/12	THIRD ANGLE PROJECTION		UNITS OF MEASURE MM
DESCRIPTION <b>INSTL-SURGE TANK MOUNTING</b>								
SUPPLEMENTAL DESCRIPTION 267A1								
ITEM/DRAWING NUMBER <b>D05-31076</b>						REVISION LETTER <b>C</b>	PAGE 1 of 3	

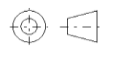
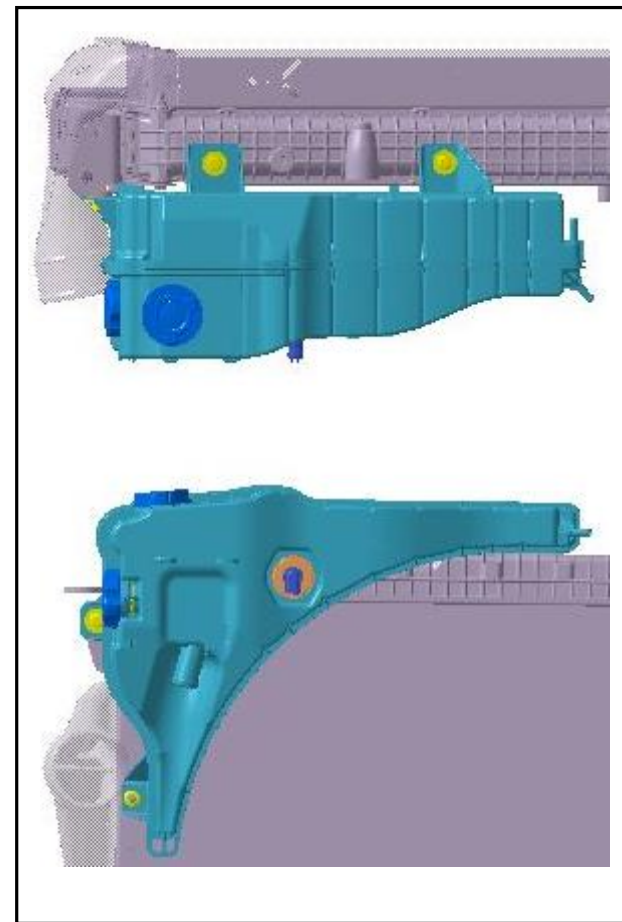
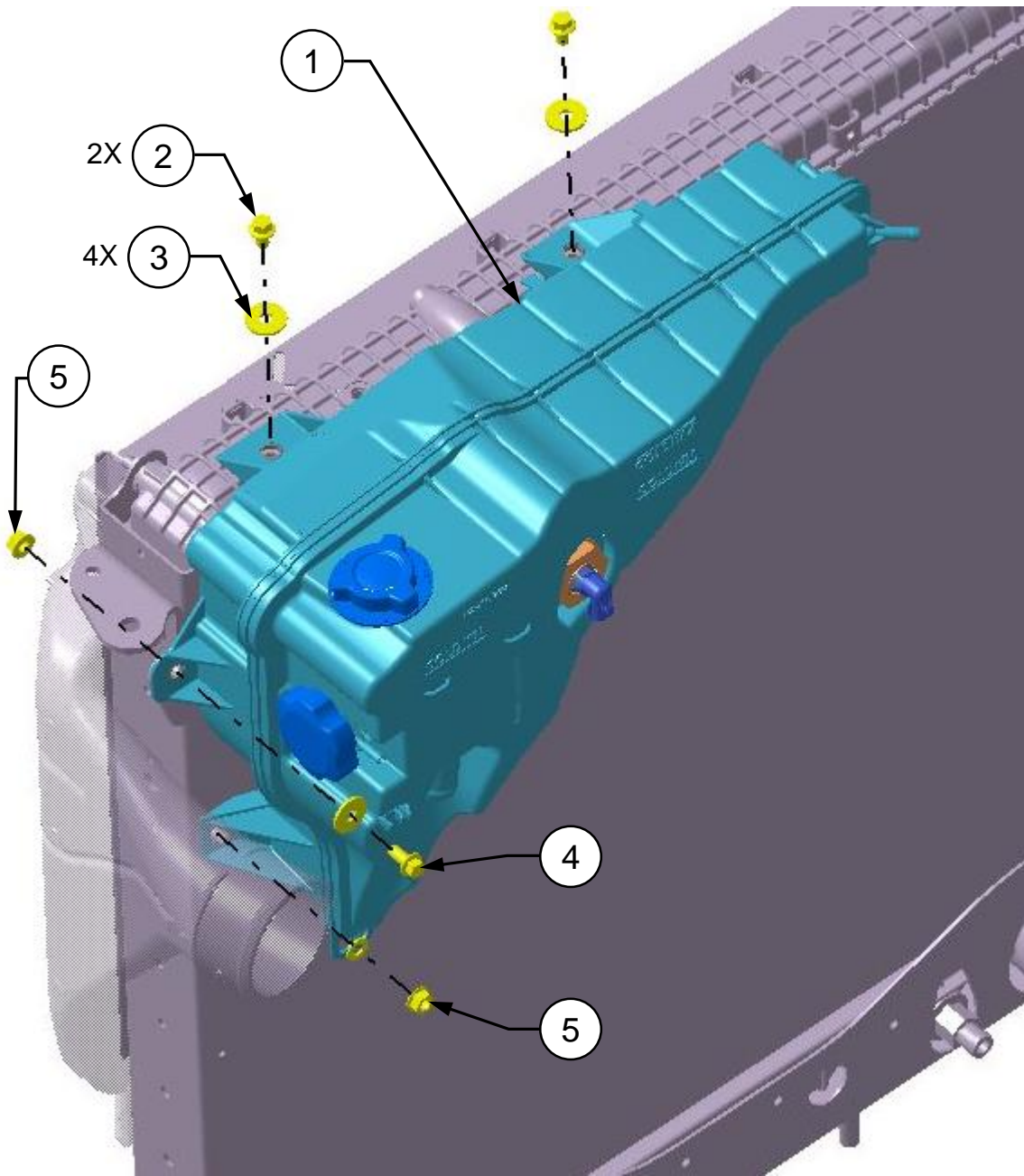

-000

REF MOD  
266

ITEM/DRAWING NUMBER	REVISION LETTER	PAGE
D05-31076	C	2 of 3

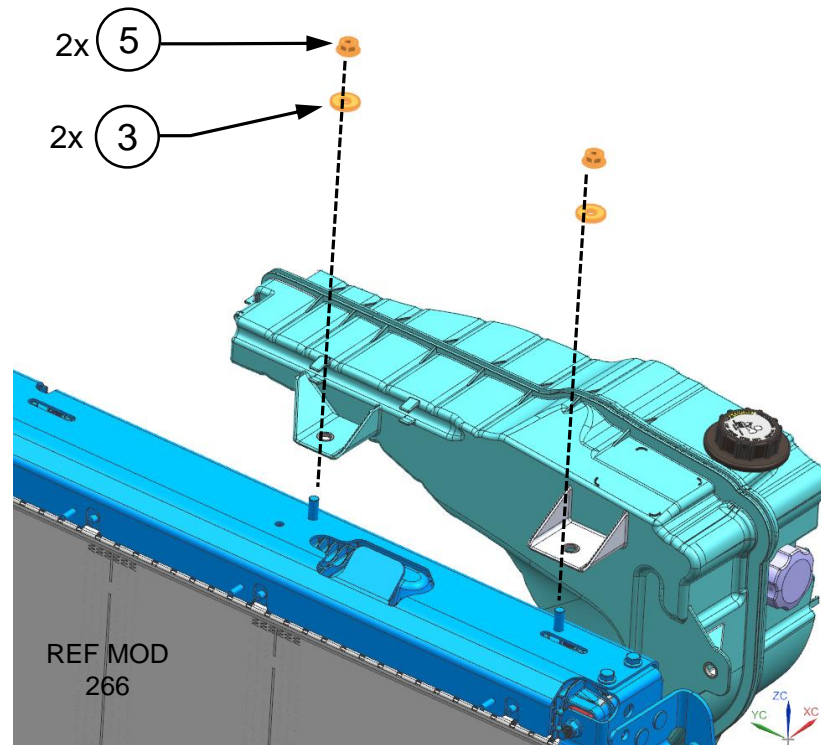
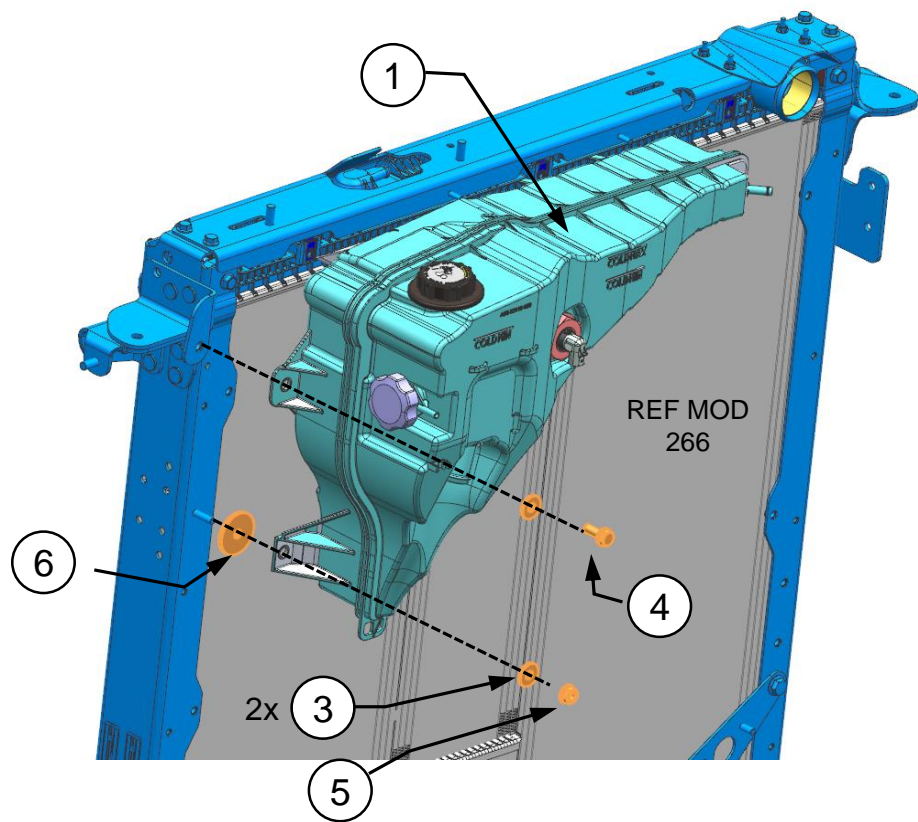

-001