

# FREIGHTLINER<sup>®</sup> LLC

THE INFORMATION CONTAINED HEREIN IS PROPRIETARY DATA, AND IS NOT FOR DISSEMINATION OR DISCLOSURE, IN WHOLE OR IN PART, FOR ANY PURPOSE OTHER THAN THAT FOR WHICH IT IS SUBMITTED, EXCEPT AS AUTHORIZED IN WRITING BY FREIGHTLINER LLC.

|                                 |          |                     |                 |
|---------------------------------|----------|---------------------|-----------------|
| MATERIAL APPROVAL               | DATE     | MFG ENG/PURCH AGENT | DATE            |
| F.MENCHE                        | 09/19/06 | B.BAER              | 09/26/06        |
| DRAWN BY                        | DATE     | CHECKED BY          | DATE            |
| C.GEDRAITIS                     | 09/19/06 | D.VANHOUSE          | 09/28/06        |
| RESPONSIBLE ENGINEER            | DATE     | APPROVED BY         | DATE            |
| C.GEDRAITIS                     | 09/19/06 | F.MECNHE            | 09/19/06        |
| DESCRIPTION                     |          |                     |                 |
| INSTL-AIR CNLR, P3 125BBC, HDEP |          |                     |                 |
| SUPPLEMENTAL DESCRIPTION        |          |                     |                 |
| 192A1                           |          |                     |                 |
| ITEM/DRAWING NUMBER             |          |                     | REVISION LETTER |
| D03-36516                       |          |                     | -               |

| RELEASE NUMBER | REV LTR | REVISION DESCRIPTION | BY  | DATE     | APPD |
|----------------|---------|----------------------|-----|----------|------|
| P25288-07      | -       | INITIAL RELEASE      | C2G | 09/19/06 | FWM  |
|                |         |                      |     |          |      |
|                |         |                      |     |          |      |
|                |         |                      |     |          |      |
|                |         |                      |     |          |      |
|                |         |                      |     |          |      |
|                |         |                      |     |          |      |
|                |         |                      |     |          |      |
|                |         |                      |     |          |      |

SEE SMARAGD ARRANGEMENT FOR 3D GEOMETRY

REF MOD 190

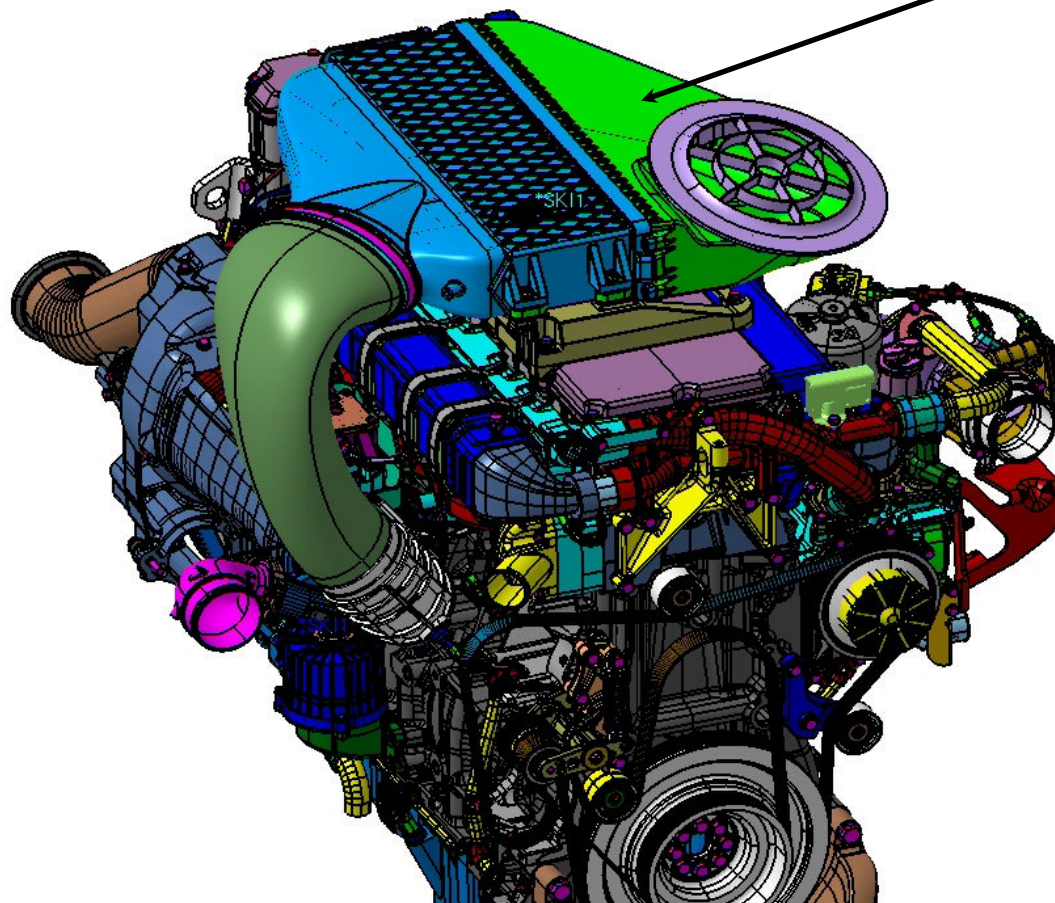

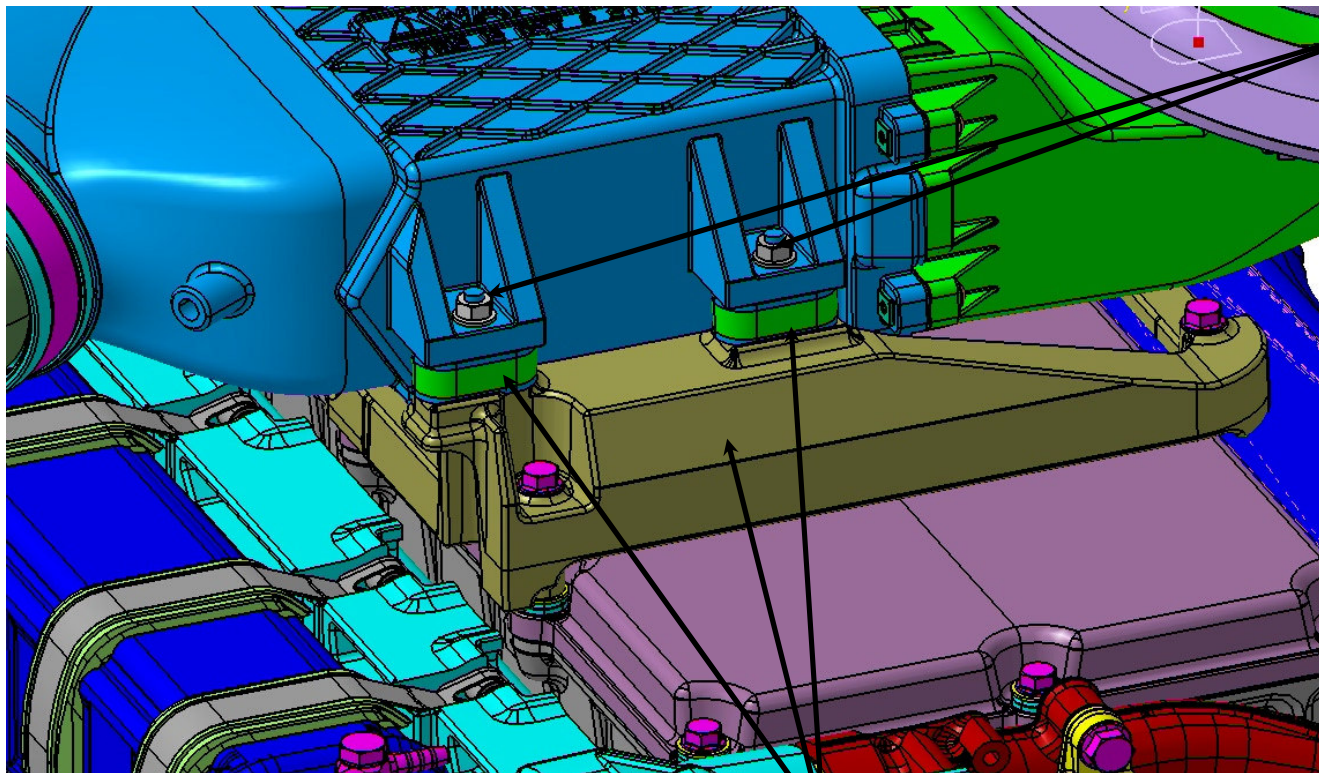

2X 04  
TORQUE 18 NM

Isolators and Bracket  
Supplied on Engine

